

3/4" HEX DRIVER FOR COVER REMOVAL

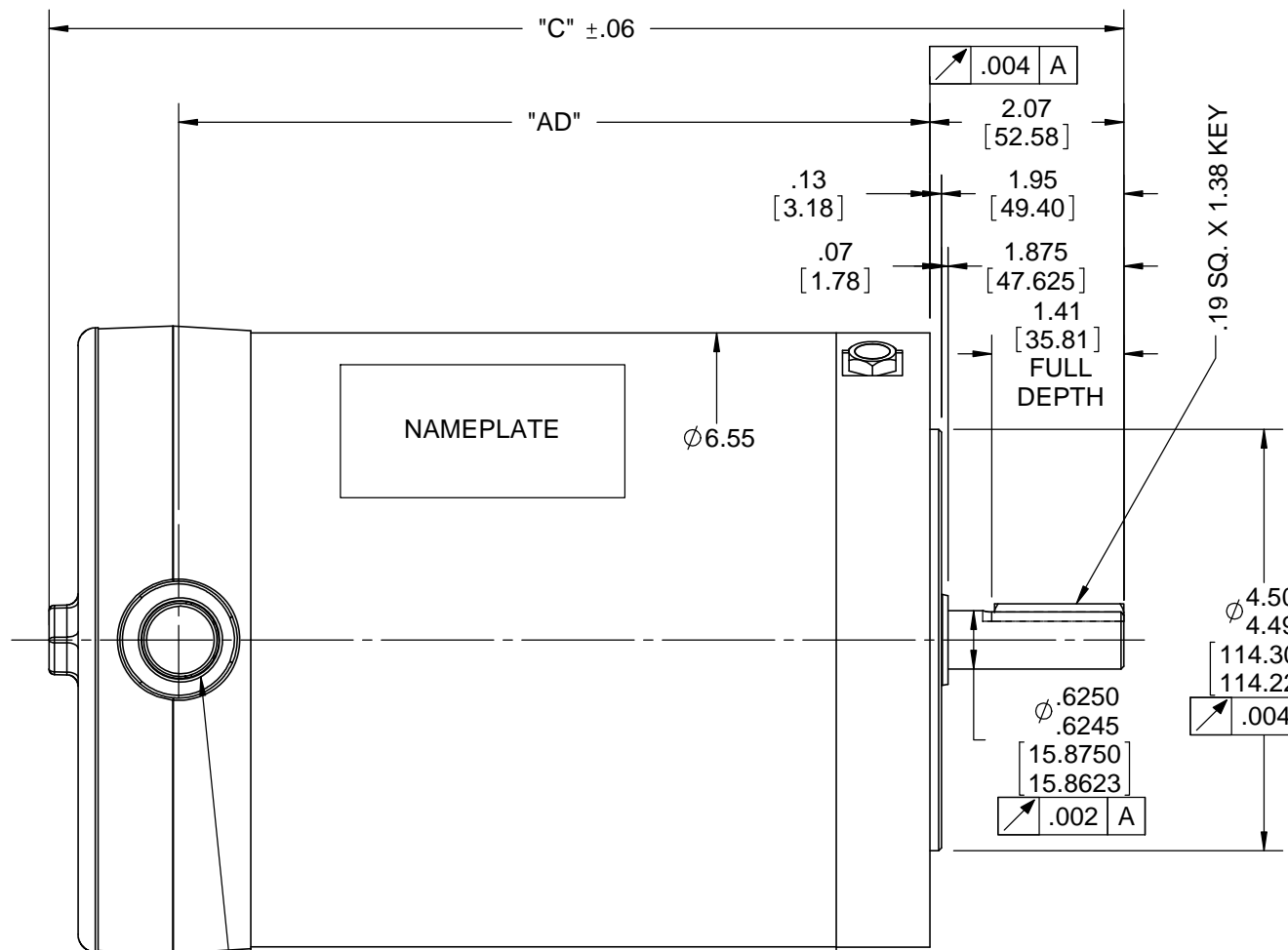

1/2-14 NPT CONDUIT HOLE (PLUGGED)

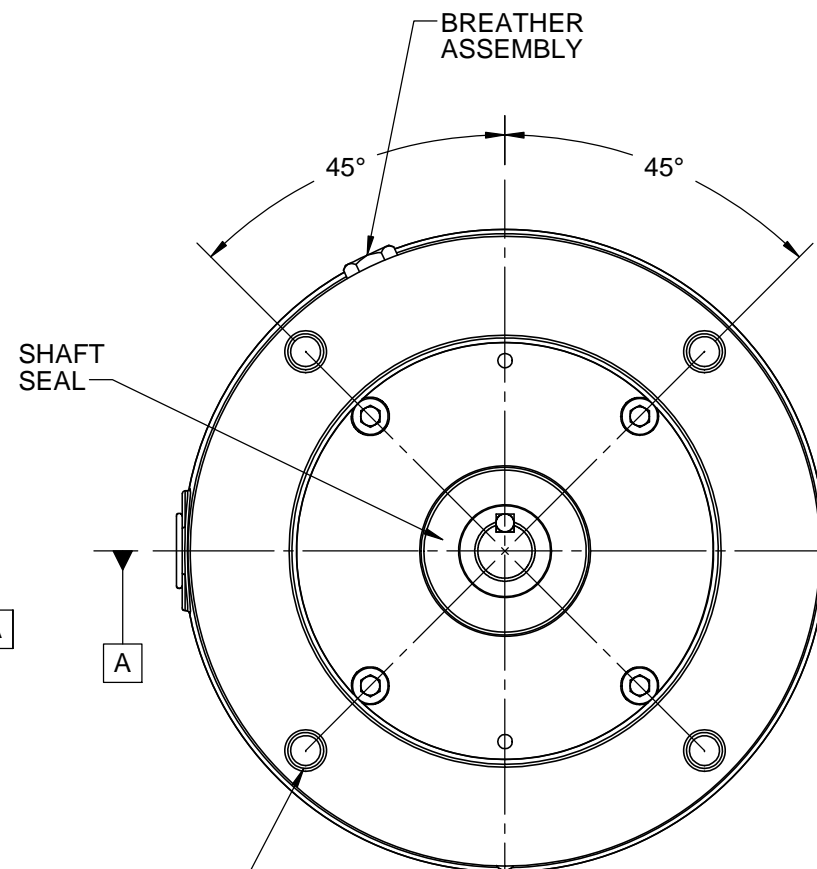

(4) 3/8-16 UNC-2B X .56 DEEP ON A Ø5.875 B.C.

| DASH NO. | "C"   | "AD" |
|----------|-------|------|
| 525      | 10.47 | 7.00 |
| 550      | 10.72 | 7.25 |
| 575      | 10.97 | 7.50 |
| 600      | 11.22 | 7.75 |
| 625      | 11.47 | 8.00 |
| 650      | 11.72 | 8.25 |
| 675      | 11.97 | 8.50 |
| 700      | 12.22 | 8.75 |
| 750      | 12.72 | 9.25 |
| 800      | 13.22 | 9.75 |

|   |                   |                    |
|---|-------------------|--------------------|
| DRAWING REVISION<br>D   | REVISION BY<br>AS | DATE<br>05/04/2017 |
| ECO<br>ECO-0123079  | APPROVED BY<br>JD | DATE<br>05/04/2017 |
| ECO DESCRIPTION<br>ADDED ITEM # 800 & PLUGGED CONDUIT HOLE  |                   |                    |
| <small>COPYRIGHT REGAL BELOIT AMERICA, INC. ALL RIGHTS RESERVED.<br/>         PROPRIETARY AND CONFIDENTIAL INFORMATION - THIS DOCUMENT IS THE PROPERTY OF<br/>         REGAL BELOIT AMERICA, INC. ("OWNER") AND CONTAINS OWNER'S PROPRIETARY<br/>         INFORMATION. ANY PERSON, CORPORATION OR OTHER FIRM RECEIVING IT IS DEEMED,<br/>         BY RECEIVING IT, TO AGREE THAT IT, AND/OR ANY PART OF IT, SHALL NOT BE DISCLOSED<br/>         TO ANY PERSON, CORPORATION OR OTHER ENTITY, DUPLICATED, AND/OR USED, EXCEPT<br/>         AS EXPRESSLY APPROVED IN WRITING IN ADVANCE BY OWNER. THIS DOCUMENT SHALL<br/>         BE RETURNED TO OWNER UPON REQUEST. IT MAY BE SUBJECT TO CERTAIN<br/>         RESTRICTIONS UNDER APPLICABLE EXPORT CONTROL LAWS AND REGULATIONS.</small> |                   |                    |

|  |         |           |         |
|--|---------|-----------|---------|
| TOLERANCES UNLESS OTHERWISE SPECIFIED:                         |         |           |         |
| DEC.   | INCH    | mm        | ANGLE   |
| .X   | ±0.1    | [±2.5]    | ±7° 30" |
| .XX  | ±0.03   | [±0.76]   |         |
| .XXX   | ±0.005  | [±0.127]  |         |
| .XXXX  | ±0.0005 | [±0.0127] |         |
| REMOVE BURRS & BREAK SHARP EDGES: .003/.015 [0.076/.381] X 45° |         |           |         |
| CORNER FILLETS: R.02 [51]                                      |         |           |         |
| MACHINED SURFACES: 200 INCH/mm 5.1                             |         |           |         |
| mm SHOWN IN [BRACKETS]   |         |           |         |

|                        |                        |
|------------------------|------------------------|
| DRAWN BY<br>LST 1/9/09 | DATE                   |
| APPROVED BY            | DATE                   |
| REFERENCE              | THIRD ANGLE PROJECTION |

|   |                                       |
|---|---------------------------------------|
| <b>REGAL</b> ™ Regal Beloit America, Inc. |                                       |
| DESCRIPTION                               | <b>OUTLINE</b><br>TENV ROUND "C" FACE |
| MATERIAL                                  | PROCESS/FINISH                        |
| SIZE<br><b>B</b>                          | DRAWING NUMBER<br><b>028942</b>       |
| SHEET<br>1 OF 1                           |                                       |