

SHEET 4

REV 4

SIZE DRAWING NO. A

THIRD ANGLE PROJECTION

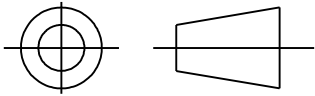

REVISIONS

| REV. | DESCRIPTION                           | DATE     | APPROVED |
|------|---------------------------------------|----------|----------|
| 3    | ADDED PART #3                         | 03/01/07 | MADHU    |
| 4    | UPDATED AS PER SAMPLE REPORT DS-1914. | 09/15/11 | KARTHIK  |

52A109641

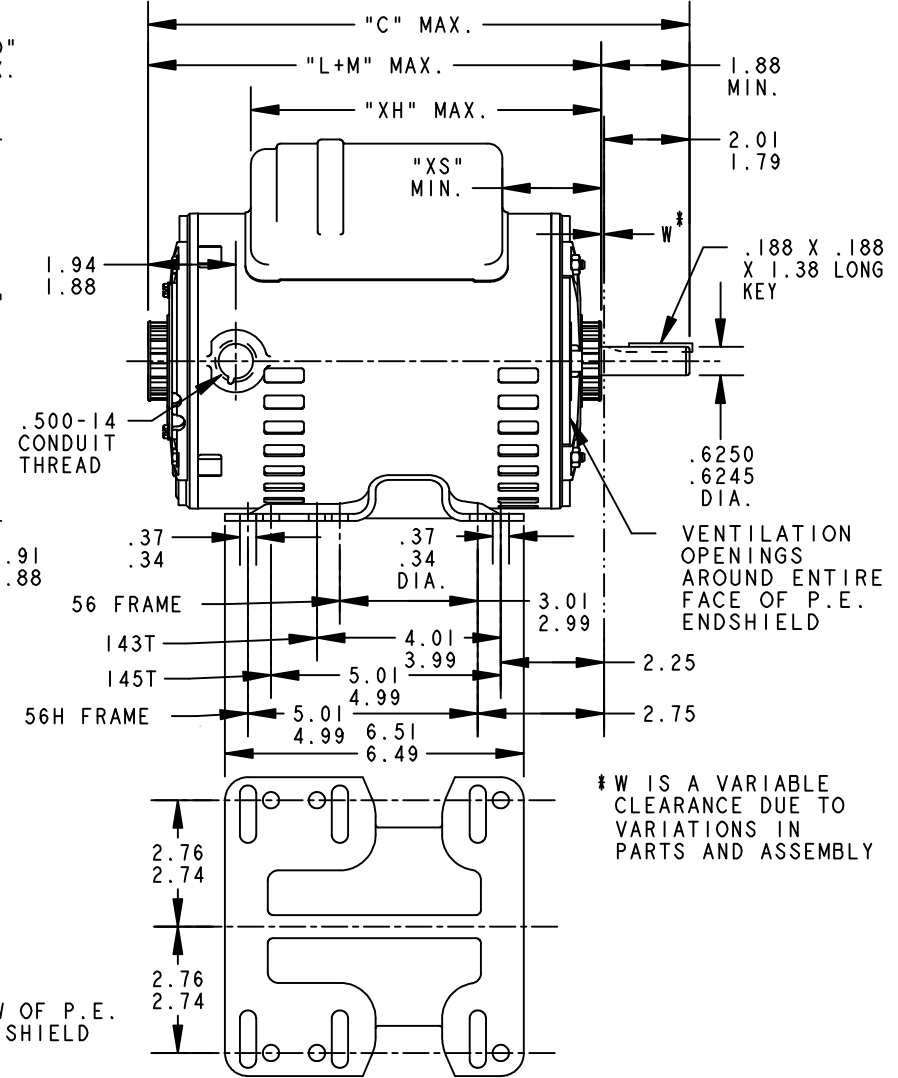
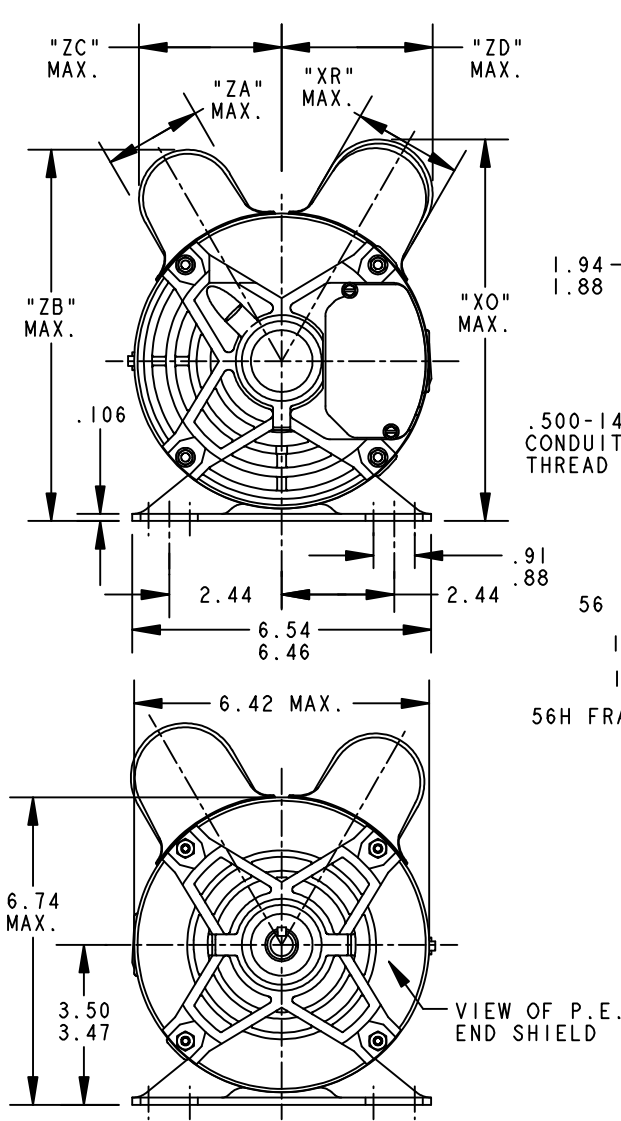

|   |      |          |         |       |       |      |      |      |      |      |      |      |      |            |
|---|------|----------|---------|-------|-------|------|------|------|------|------|------|------|------|------------|
| 3 | KCR  | 49       | 56H     | 15.04 | 13.04 | 9.74 | 8.39 | 2.40 | 4.08 | 2.40 | 8.39 | 3.46 | 3.33 | 10.71      |
| 2 | KCR  | 49       | 56H     | 15.04 | 13.04 | 9.74 | 8.39 | 2.40 | 4.05 | 2.10 | 8.16 | 3.15 | 3.33 | 10.71      |
| 1 | KCR  | 49       | 56H     | 13.96 | 11.96 | 9.67 | 8.39 | 2.40 | 4.00 | 2.10 | 8.16 | 3.15 | 3.33 | 9.63       |
| P | TYPE | RBC SIZE | NEMA FR | "C"   | "L+M" | "XH" | "XO" | "XR" | "XS" | "ZA" | "ZB" | "ZC" | "ZD" | MIN. SHELL |

|  |                        |          |          |   |
|--|------------------------|----------|----------|---|
| FOR ADDITIONAL INFO REFER TO:<br>APPLIED PRACTICES<br>DIMENSIONS ARE IN INCHES | SIGNATURES             |          | DATE     |  <p><b>REGAL-BELOIT CORPORATION</b></p> <p>TITLE<br/><b>OUTLINE</b><br/><b>40 FRAME REDESIGN - GENERAL PURPOSE MOTOR - DRIP PROOF - BALL BEARING - WELDED BASE</b></p> |
|  | MODEL                  | M.D.PAPE | 06/28/94 |   |
|  | DETAIL                 | .        | .        |   |
|  | CHECKED                | .        | .        |   |
|  | ENGRG                  | .        | .        | SIZE DRAWING  |
|  | MFG                    | .        | .        | <b>52A109641</b>  |
|  | QUALITY                | .        | .        | REV   |
|  | ISSUED                 | M.D.PAPE | 06/28/94 | <b>4</b>  |
| MATERIAL   | SOLID MODEL: 52A109641 |          |          | SCALE: 0.250 REF. No: .   |
|  |                        |          |          | SHEET 1 of 1  |