

M8-1.25 x 19MM DEEP R.H. THREADED SHAFT
 (4) $\phi 12.00^{+0.43}_{-0.00}$ THRU HOLE ON A $\phi 165.0$ B.C.

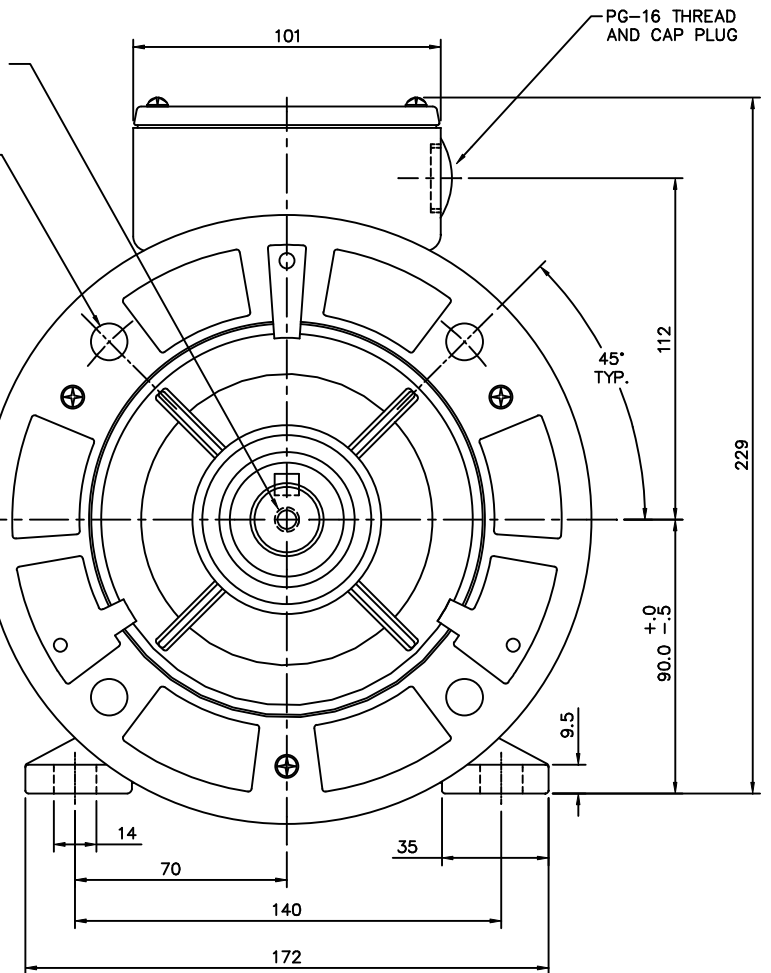

FRAME DESIGN	"B"	"BB"	"CB"
90L	125±0.7	150	91
90S	100±0.7	125	79
XXX	XXX	XXX	XXX

		TOLERANCES UNLESS SPECIFIED		MARATHON ELECTRIC		DRAWN JGO 01/28/05	
		DEC.	METRIC			CHK	
		.X	±2.5	TITLE		APPD	
		.XX	±.76	METRIC OUTLINE, IMB35		SCALE 1=1.6	
		.XXX	±.127	IEC-90 FRAME RIGID W/B5 FLANGE		REF OSVC-300-567	
		.XXXX	±.0127	MAT'L ALUMINUM		FMF MARATHON STOCK	
NO.	REVISION	BY & DATE	CHK	ANG	FINISH	PREV	
			RFP		CAD FILE 16987000ME	SIZE B	
	THIS DRAWING IN DESIGN AND DETAIL IS OUR PROPERTY AND MUST NOT BE USED EXCEPT IN CONNECTION WITH OUR WORK ALL RIGHTS OF DESIGN AND INVENTION ARE RESERVED THIS IS AN ELECTRONICALLY GENERATED DOCUMENT - DO NOT SCALE THIS PRINT				DIST	DRAWING NO. 169870-00ME	REV.