

TYPE HS SQUIRREL CAGE INDUCTION MOTOR ENCLOSURE - TOTALLY ENCLOSED FAN COOLED AND EXPLOSION PROOF BEARING - ANTI-FRICTION AND SOLID SLEEVE

- NOTES
- A- THIS DRAWING IS NOT TO BE REGARDED AS INDICATING EXACT DETAILS OF CONSTRUCTION. IT IS PROPERLY DIMENSIONED FOR ERECTION PURPOSES ONLY.
 - B- AIR INLET OPENING ON END OF MOTOR. WHEN INSTALLING MOTOR AVOID LOCATING MOTOR SO THAT ADJACENT STRUCTURES ARE CLOSER THAN 12 INCHES TO MOTOR ENDS. ALSO THAT NO ADJACENT STRUCTURE CAUSES EXHAUST AIR TO BE DIRECTED INTO INLET OPENINGS.
 - C- MOUNTING BOLTS, DOWELS AND COUPLING NOT SUPPLIED BY E.T.I. UNLESS SPECIFICALLY ORDERED.
 - D- EACH FOOT MUST BE MOUNTED ON A BASE EQUAL TO OR LARGER THAN THE PAD AREA.
 - E- SLEEVE BEARINGS HAVE 0.50 MINIMUM ENDFLOAT. COUPLING ENDFLOAT SHOULD BE 0.19 MAXIMUM WITH ROTOR LOCATED ON MECHANICAL CENTERLINE.
 - F- FOR MOUNTING OF MOTOR USE .875-9 THD/INCH HOLD DOWN BOLTS.
 - G- NON DRIVE END BEARING INSULATED.
- DEVICES

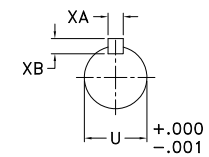
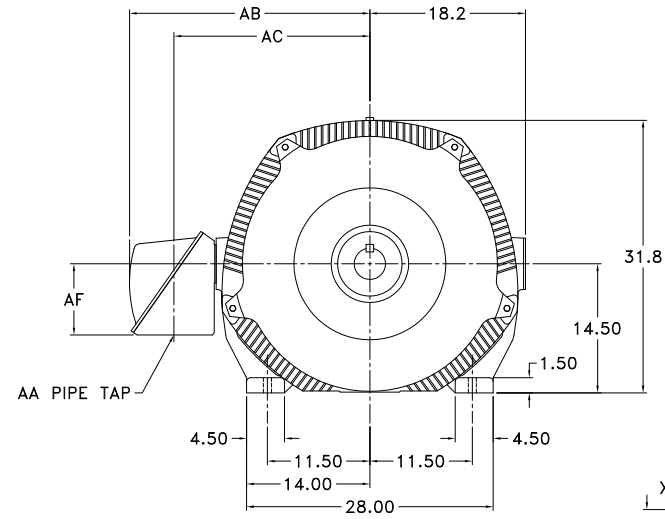
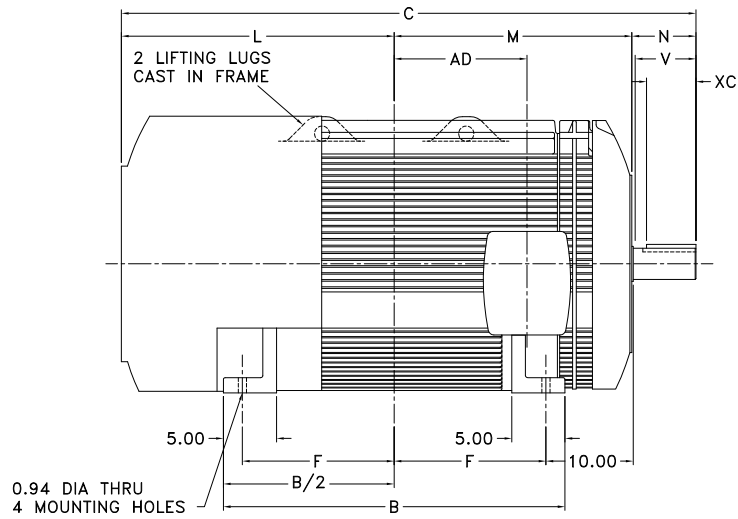

END VIEW OF SHAFT

FRAME SIZE	REAR SHAFT EXTENSION										RECOMMENDED COUPLING BORE		APPROX WEIGHT		
	U	KEY SIZE			N	V	B	C	F	L	M	AD		MIN.	MAX.
		XA	XB	XC											
5809H	2.875	.750	.750	4.00	5.76	5.50	35.5	61.56	16.00	29.80	26.00	14.50	2.8730	2.8740	5400
5809S	3.375	.875	.875	5.00	6.76	6.50	35.5	62.56	16.00	29.80	26.00	14.50	3.3720	3.3735	5400
5809L	3.875	1.000	1.000	6.00	7.76	7.50	35.5	63.56	16.00	29.80	26.00	14.50	3.8720	3.8735	5400
5809U	4.125	1.000	1.000	10.62	12.38	12.12	35.5	68.18	16.00	29.80	26.00	14.50	4.1215	4.1230	5450
5810H	2.875	.750	.750	4.00	5.76	5.50	39.5	65.56	18.00	31.80	28.00	16.50	2.8730	2.8740	6150
5810S	3.375	.875	.875	5.00	6.76	6.50	39.5	66.56	18.00	31.80	28.00	16.50	3.3720	3.3735	6150
5810L	3.875	1.000	1.000	6.00	7.76	7.50	39.5	67.56	18.00	31.80	28.00	16.50	3.8720	3.8735	6150
5810U	4.125	1.000	1.000	10.62	12.38	12.12	39.5	72.18	18.00	31.80	28.00	16.50	4.1215	4.1230	6200
5811H	2.875	.750	.750	4.00	5.76	5.50	43.5	69.56	20.00	33.80	30.00	18.50	2.8730	2.8740	6900
5811S	3.375	.875	.875	5.00	6.76	6.50	43.5	70.56	20.00	33.80	30.00	18.50	3.3720	3.3735	6900
5811L	3.875	1.000	1.000	6.00	7.76	7.50	43.5	71.56	20.00	33.80	30.00	18.50	3.8720	3.8735	6900
5811U	4.125	1.000	1.000	10.62	12.38	12.12	43.5	76.18	20.00	33.80	30.00	18.50	4.1215	4.1230	6950

CONDUIT BOX							
FAN COOLED - STANDARD				EXPLOSION PROOF			
AA	AB	AC	AF	AA	AB	AC	AF
3.00	28.94	23.09	9.38	3.00	32.31	24.00	13.00

THESE DRAWINGS ARE PREPARED IN ACCORDANCE WITH THE NORMAL AND ACCEPTED STANDARDS WITHIN THE ELECTRICAL INDUSTRY FOR THE PURPOSE OF OBTAINING CUSTOMER APPROVAL AS PART OF THE MANUFACTURING OR PRODUCTION PROCESS. ANY USE OR COMMUNICATION OF THE DRAWINGS BY THE CUSTOMER (OTHER THAN FOR GRANTING APPROVAL) SHALL BE THE SOLE RESPONSIBILITY OF THE CUSTOMER.

THE INFORMATION CONTAINED HEREIN WHICH IS THE PROPERTY OF TOSHIBA INDUSTRIAL PRODUCTS CANADA - THIS MUST BE MAINTAINED IN CONFIDENTIAL AND NO PORTION OF THIS DRAWING MAY BE REPRODUCED OR USED WITHOUT THE EXPRESS PERMISSION OF THE COMPANY.

TOSHIBA INDUSTRIAL PRODUCTS CANADA **TOSHIBA**

TITLE: TYPE HS MOTOR FRAME 5800

OUTLINE - TEFC/TEXP ENCLOSURE

SCALE: N.T.S. SHEET: OF

DESIGNED BY: N.WEST DATE: 10/9/78

CHECKED BY: DATE:

PRELIMINARY SHAFT AND MOUNTING ONLY

G.O. _____ S.O. _____ CUST. ORDER _____

CUST. _____

RATING: _____

PER: _____ DATE _____

TOSHIBA INDUSTRIAL PRODUCTS CANADA, STONEY CREEK

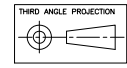

REVISION	STANDARD
1	