

TYPE HS SQUIRREL CAGE INDUCTION MOTOR  
ENCLOSURE - TOTALLY ENCLOSED FAN COOLED  
AND EXPLOSION PROOF  
BEARING - ANTI-FRICTION

NOTES

- A- THIS DRAWING IS NOT TO BE REGARDED AS INDICATING EXACT DETAILS OF CONSTRUCTION. IT IS PROPERLY DIMENSIONED FOR ERECTION PURPOSES ONLY.
- B- MOUNTING BOLTS, DOWELS AND COUPLING NOT SUPPLIED BY TOSHIBA UNLESS SPECIFICALLY ORDERED.
- C- WHEN MOUNTING MOTOR, SHIM COMPLETE FOOT PAD AREA.
- D- ANTI-FRICTION BEARINGS MUST BE REGREASED WHILE MOTOR IS RUNNING.
- E- FOR MOUNTING OF MOTOR USE .875-9 THD/INCH HOLD DOWN BOLTS.
- F- NON DRIVE END BEARING INSULATED.

DEVICES

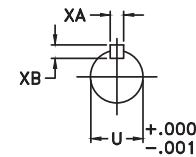
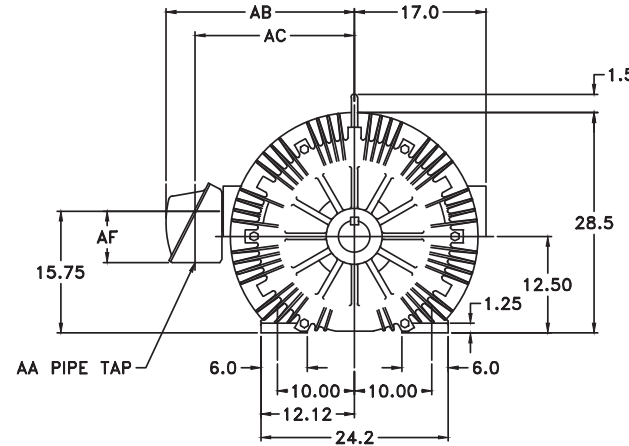
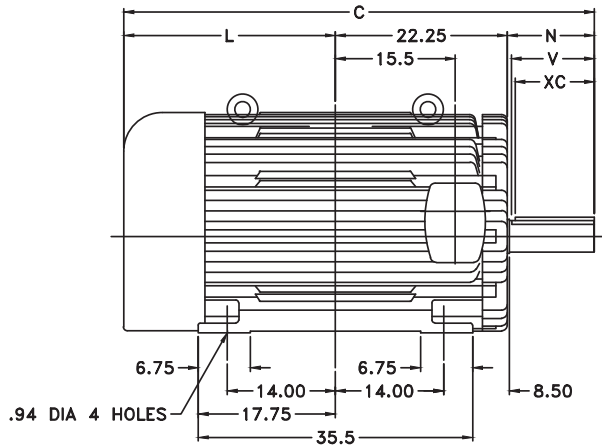

END VIEW OF SHAFT

FRAME SIZE	REAR SHAFT EXTENSION					RECOMMENDED COUPLING BORE		APPROX WEIGHT			
	U	KEY SIZE			N	V	C		L	MIN.	MAX.
D509US	2.375	.625	.625	3.00	4.69	4.25	54.31	27.38	2.3730	2.3740	4000
D509E	2.875	.625	.625	3.75	5.12	4.62	54.75	27.38	2.8730	2.8740	4000
D509G	4.125	.875	.875	10.25	11.25	10.75	60.88	27.38	.....	.....	4000
D509H	5.000	1.250	1.250	11.00	13.25	12.75	62.88	27.38	.....	.....	4000
H509US	2.375	.625	.625	3.00	4.69	4.25	59.81	32.88	2.3730	2.3740	5000
H509E	2.875	.625	.625	3.75	5.12	4.62	60.25	32.88	2.8730	2.8740	5000
H509G	4.125	.875	.875	10.25	11.25	10.75	66.38	32.88	.....	.....	5000
H509H	5.000	1.250	1.250	11.00	13.25	12.75	68.38	32.88	.....	.....	5000

CONDUIT BOX							
FAN COOLED - STANDARD				EXPLOSION PROOF			
AA	AB	AC	AF	AA	AB	AC	AF
3.00	24.38	20.62	6.63	3.00	25.06	20.44	7.00
FAN COOLED - ALTERNATE							
3.50	28.38	22.50	9.38				

THIS DRAWING WAS PREPARED IN ACCORDANCE WITH THE NORMAL AND ACCEPTED STANDARDS WITHIN THE ELECTRICAL INDUSTRY FOR THE PURPOSE OF OBTAINING CUSTOMER APPROVAL. AS PART OF THE MANUFACTURING OR PRODUCTION PROCESS, ANY USE OR COMPARISON OF THIS DRAWING BY THE CUSTOMER CONCERNING THE DRAWING APPROVAL SHALL BE THE SOLE RESPONSIBILITY OF THE CUSTOMER.

THE INFORMATION CONTAINED HEREIN IS THE PROPERTY OF TOSHIBA INDUSTRIAL PRODUCTS CANADA. IT IS TO BE KEPT IN CONFIDENTIALITY AND NO PART OF THE INFORMATION HEREIN IS TO BE REPRODUCED OR USED WITHOUT THE EXPRESS WRITTEN PERMISSION OF TOSHIBA INDUSTRIAL PRODUCTS CANADA.

TOSHIBA INDUSTRIAL PRODUCTS CANADA

TITLE TYPE HS MOTOR FRAME D509/H509

OUTLINE - TEFC/TEXP ENCLOSURE

DRAWING IN SHEET SCALE: N.T.S. SHEET: 1 OF 1

DATE: N.WEST DATE: APPROX DATE: APPROX

DATE: APPROX DATE: APPROX

E10D118

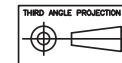

STANDARD REVISIONS  
ISSUE 1