

ROTATION
SEE NOTE 6

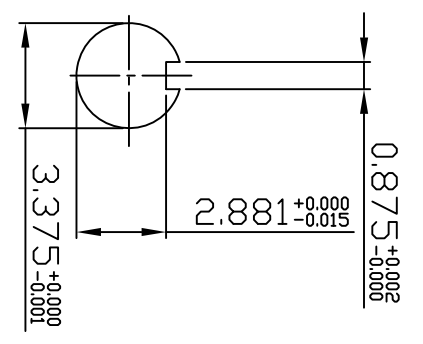
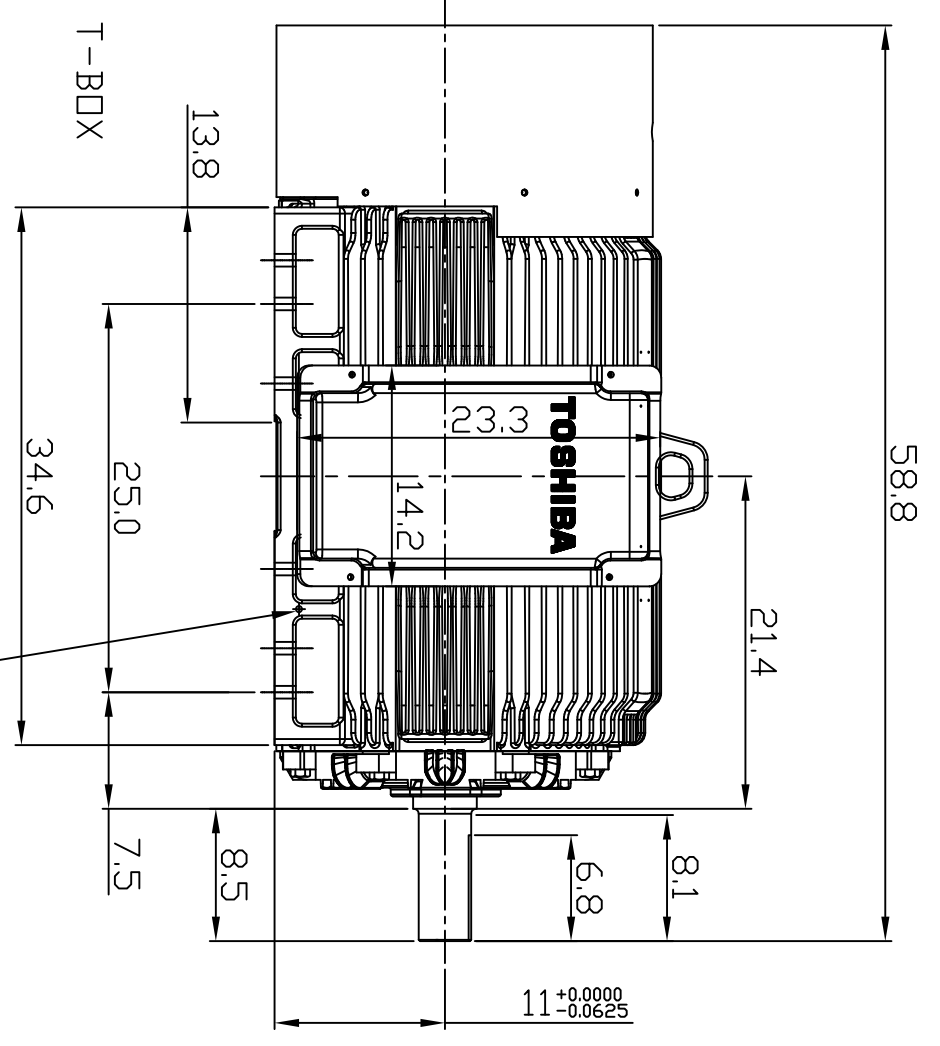
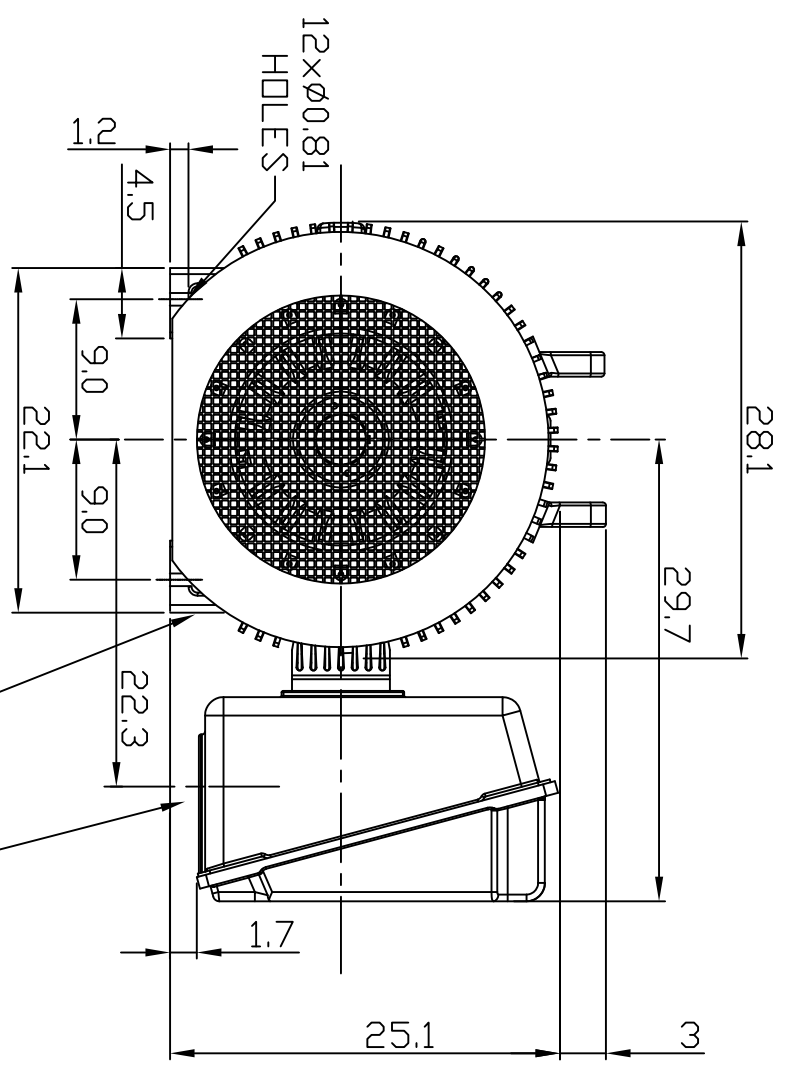

TECHNICAL INFORMATION

1. BEARING LUBRICATION DE: CHEVRON SRI
ODE: CHEVRON SRI
2. BEARING TYPE DE: NU322C3
ODE: 6318C3
3. WINDING TEMP. DETECTORS
NUMBER AND TYPE: N/A
LOCATION: N/A
4. BEARING TEMP. DETECTORS
NUMBER AND TYPE: N/A
5. SPACE HEATER N/A PHASE
VOLTS: - WATTS: -
6. ROTATION: CCW VIEWED FROM NON DRIVE END
THIS MOTOR IS BI DIRECTIONAL
7. MOTOR PAINT COLOR: GRAY
8. APPROX. WEIGHT: 3800 Lbs
9. ACCESSORIES:

GROUND TERMINAL

GROUND TERMINAL

DRAWING LIST

MAIN TERMINAL BOX 130-7622-55	
AUX TERMINAL BOX FOR	
SPACE HEATER	-
R.T.D.	-
THERMISTOR	-
PRODUCTION #	-
UNITS:	INCHES

MOTOR OUTLINE FOR THREE PHASE INDUCTION MOTOR

NO.	REVISION	BY	DATE

CUSTOMER NAME		P.O. NO.		MOTOR TAG NO.	
OUTPUT	HP	POLE	4/6	VOLTAGE	2.3/4k V
TYPE	TIKK	FORM	FBKW1	INS. CLASS	F
FREQUENCY	Hz	RATING	CONT.	FRAME	N449T
FULL LOAD SPEED	(min ⁻¹)	S.F.		ENCLOSURE	TEFC

TOSHIBA INTERNATIONAL CORPORATION
HOUSTON, TEXAS U.S.A.

3rd ANGLE PROJ.	PREPARED BY: T. Ziebro	DATE: 2/26/04	CHECKED BY:	DATE:	DRAWING NO.: MDSL0071-13	REV. 0
-----------------	------------------------	---------------	-------------	-------	--------------------------	--------