

$\phi 3/4$ "-10 UNC 4 PLACES FOR JACKING BOLTS

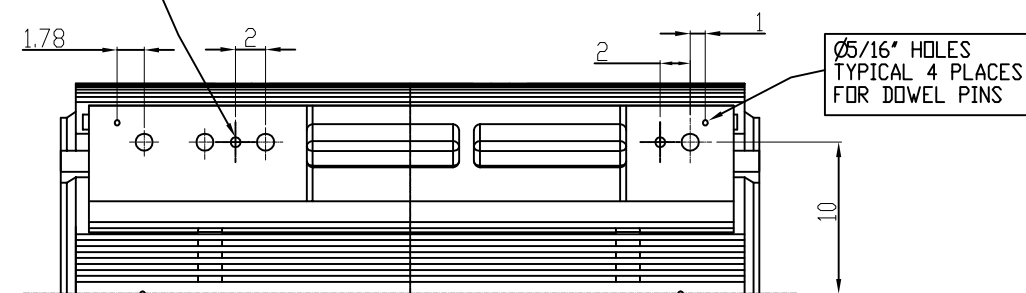

UNITS: INCHES

**TECHNICAL INFORMATION**

- BEARING LUBRICATION DE: TURBINE OIL ISO VG32  
ODE: TURBINE OIL ISO VG32
- BEARING TYPE DE: M9-90 INS  
ODE: M9-90 INS
- WINDING TEMP. DETECTORS  
NUMBER AND TYPE: 6xRTD(Pt0°C-100ohm)  
LOCATION: IN STATOR SLOT
- BEARING TEMP. DETECTORS  
NUMBER AND TYPE: \_\_\_\_\_
- SPACE HEATER 1 PHASE  
VOLTS: 120 WATTS: 240
- ROTATION: CCW VIEWED FROM NON DRIVE END  
THIS MOTOR IS BI DIRECTIONAL
- MOTOR PAINT COLOR: GRAY
- APPROX. WEIGHT: 5000 Lbs
- ACCESSORIES:

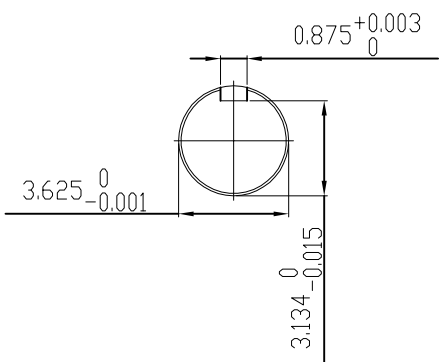

DRAWING LIST	
MAIN TERMINAL BOX	130-7622-55
AUX TERMINAL BOX FOR	
SPACE HEATER	130-7520-50
R.T.D.	130-7522-51
THERMISTOR	N/A
PRODUCTION #	N/A

1	JACKING TO INLINE ADD DOWELS	RWS	1/6/14
0	FIRST ISSUE	BCS	7/15/09
NO.	REVISION	BY	DATE

MOTOR OUTLINE FOR THREE PHASE INDUCTION MOTOR						
CUSTOMER NAME			P.O. NO.	MOTOR TAG NO.		
OUTPUT HP	POLE	VOLTAGE V	FREQUENCY Hz	FULL LOAD SPEED (min <sup>-1</sup> )	TOSHIBA MODEL NO.	
TYPE	FORM	INS. CLASS	RATING	FRAME	S.F.	ENCLOSURE
		F	CONT.	5011US		TEFC
TOSHIBA INTERNATIONAL CORPORATION HOUSTON, TEXAS U.S.A.						
3rd ANGLE PROJ.	PREPARED BY:	DATE:	CHECKED BY:	DATE:	DRAWING NO.:	REV.
	B SIDLE	7/15/09	EDDIE R.	7/16/09	MDSL0071-21	1