

CLEARANCE REQUIRED TO REMOVE HOUSING

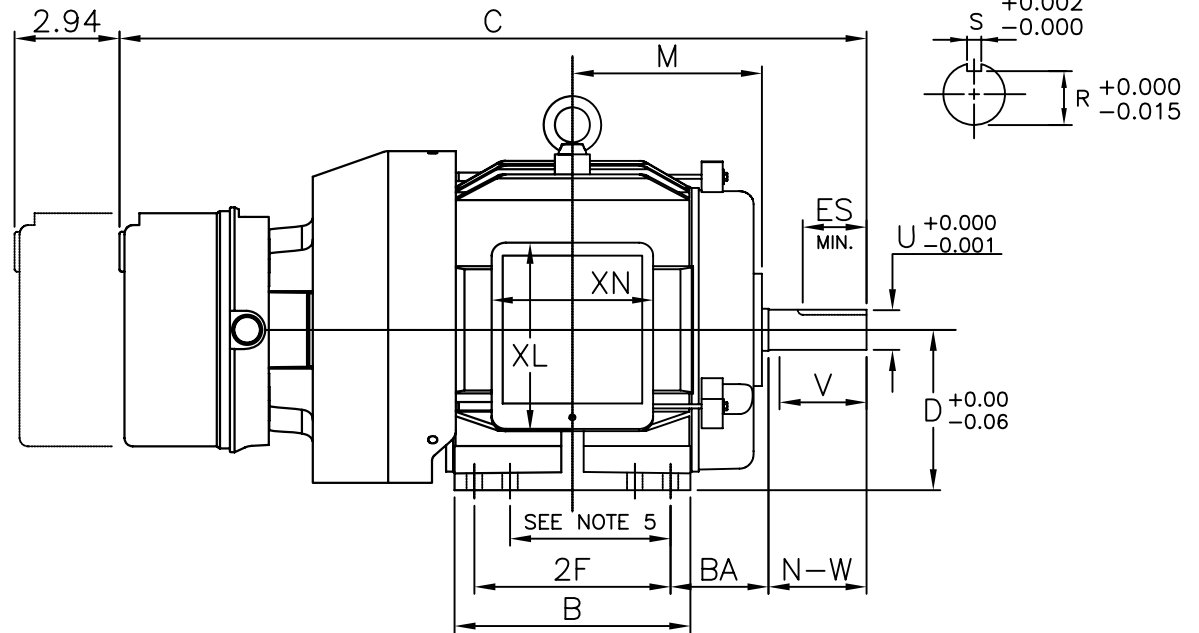
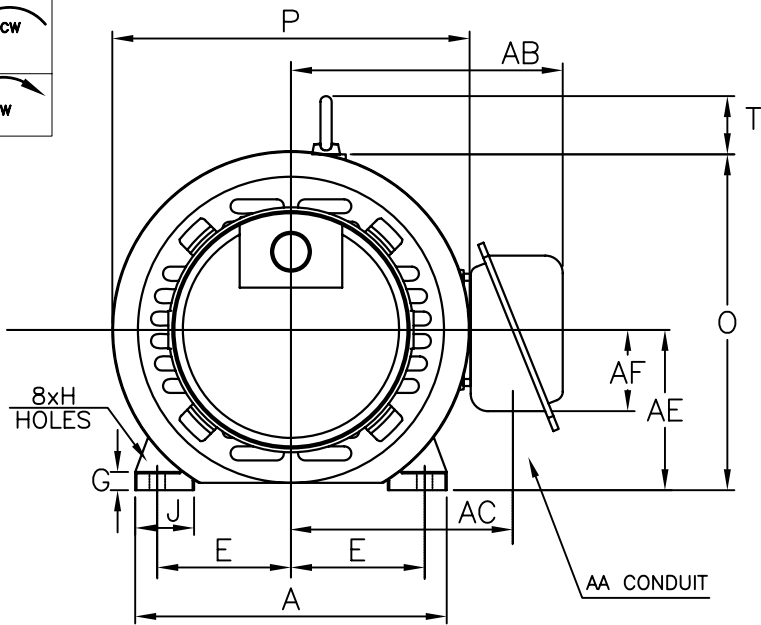

UNITS: INCHES

FRAME SIZE	MOTOR DIMENSIONS											CONDUIT BOX						
	A	B	C	D	G	J	K	M	O	P	T	AA	AB	AC	AE	AF	XL	XN
182T/184T	8.8	6.6	21.0	4.50	0.5	1.6	0	5.3	9.4	10.1	2.0	0.75	7.7	6.3	4.5	2.3	5.3	4.6

FRAME SIZE	MOUNTING			SHAFT EXTENSION				KEY SEAT			BEARINGS		MAXIMUM WEIGHT
	E	2F	H	BA	N-W	V	U	R	S	ES	LS	OS	
182T/184T	3.75	4.50/5.50	0.44	2.75	2.75	2.50	1.125	0.986	0.250	1.79	6207ZZ	6205ZZ	120 lbs.

- NOTES:
1. DIMENSION V REPRESENTS LENGTH OF STRAIGHT PART OF SHAFT
 2. MAIN CONDUIT BOX MAY BE ROTATED IN 90° INCREMENTS
 3. KEY DIMENSIONS EQUAL S x S x 1.75 (MOTOR SUPPLIED WITH KEY)
 4. MOTOR WEIGHT SHOWN IS MAXIMUM HORSEPOWER IN FRAME
 5. THIS DIMENSION EQUALS 2F FOR 182T MOUNTING
 6. STANDARD PRODUCT USE BI-DIRECTIONAL FAN. OPPOSITE ROTATION AVAILABLE ONLY BY CONNECTION CHANGE

CUSTOMER: _____ MOTOR MODEL NO.: BY1584LF2OMH

P.O. NO.: _____ HP: 1.5 VOLTAGE: 575 RPM(SYN.): 900 Hz: 60

FRAME SIZE: 184T PRODUCT TYPE: TEFC EQP III, EPACT, & HIGH EFFICIENCY BRAKE SERIES

COMMENTS: 56,000 SERIES STEARNS BRAKE

TAG NO's: _____

- STANDARD (NO AUX. BOXES)
- RTD AUX. BOX
- SPACE HEATER AUX. BOX
- BEARING RTD's

PER: _____ DATE: _____

TOSHIBA RESERVES THE RIGHT TO MAKE CHANGES OF TECHNICAL IMPROVEMENT AND THE DATA MAY CHANGE WITHOUT NOTICE PRELIMINARY

DO NOT USE FOR CONSTRUCTION, INSTALLATION, OR APPLICATION PURPOSES UNLESS THE DRAWING IS MARKED AS CERTIFIED CERTIFIED

TOSHIBA
TOSHIBA INTERNATIONAL CORPORATION

TOTALLY-ENCLOSED FAN-COOLED
HORIZONTAL FOOT-MOUNTED
3 PHASE INDUCTION MOTOR
F1 ASSEMBLY

XT SERIES
VISIT OUR WEBSITE AT:
www.toshiba.com/ind