

CLEARANCE REQUIRED TO REMOVE HOUSING

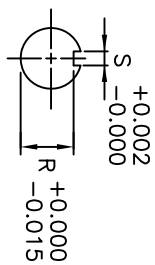
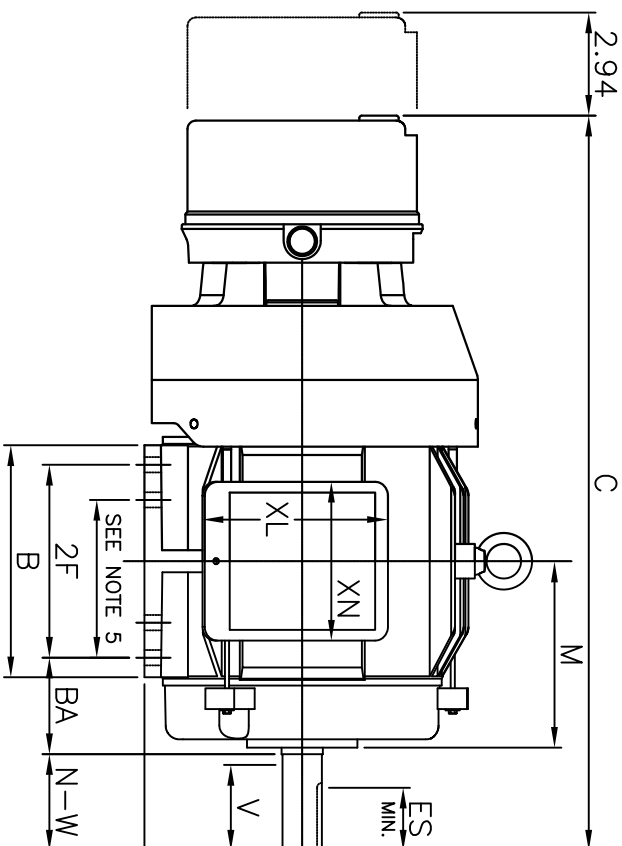
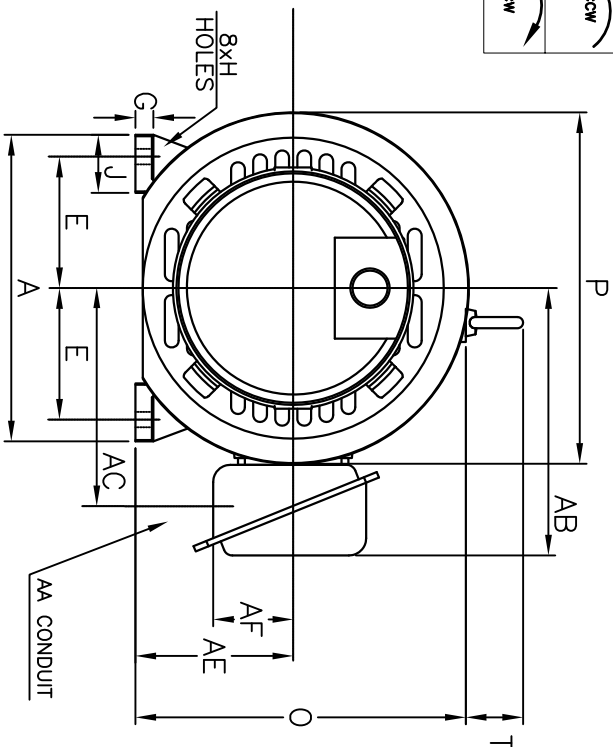

UNITS: INCHES

FRAME SIZE	MOTOR DIMENSIONS										CONDUIT BOX							
	A	B	C	D	G	J	K	M	O	P	T	AA	AB	AC	AE	AF	XL	XN
182T/184T	8.8	6.6	21.0	4.50	0.5	1.6	0	5.3	9.4	10.1	2.0	0.75	7.7	6.3	4.5	2.3	5.3	4.6

FRAME SIZE	MOUNTING				SHAFT EXTENSION				KEY SEAT			BEARINGS			MAXIMUM WEIGHT
	E	2F	H	BA	N-W	V	U	R	S	ES	LS	OS	OS		
182T/184T	3.75	4.50/5.50	0.44	2.75	2.75	2.50	1.125	0.986	0.250	1.79	6207ZZ	6205ZZ	120 lbs.		

CUSTOMER: _____ MOTOR MODEL NO.: _____

TAG NO's: _____

P.O. NO.: _____ HP: _____ RPM(SYN.): _____ Hz: _____
 VOLTAGE: _____
 FRAME SIZE: _____ PRODUCT TYPE: IEFEC EOP III, EPACK, & HIGH EFFICIENCY BRAKE SERIES
 COMMENTS: 56,000 SERIES STEARNS BRAKE

PER: _____ DATE: _____

TOSHIBA RESERVES THE RIGHT TO MAKE CHANGES OF TECHNICAL IMPROVEMENT AND THE DATA MAY CHANGE WITHOUT NOTICE PRELIMINARY
 DO NOT USE FOR CONSTRUCTION, INSTALLATION, OR APPLICATION PURPOSES UNLESS THE DRAWING IS MARKED AS CERTIFIED CERTIFIED

- NOTES:
1. DIMENSION V REPRESENTS LENGTH OF STRAIGHT PART OF SHAFT
 2. MAIN CONDUIT BOX MAY BE ROTATED IN 90° INCREMENTS
 3. KEY DIMENSIONS EQUAL S x S x 1.75 (MOTOR SUPPLIED WITH KEY)
 4. MOTOR WEIGHT SHOWN IS MAXIMUM HORSEPOWER IN FRAME
 5. THIS DIMENSION EQUALS 2F FOR 182T MOUNTING
 6. STANDARD PRODUCT USE BI-DIRECTIONAL FAN. OPPOSITE ROTATION AVAILABLE ONLY BY CONNECTION CHANGE

STANDARD (NO AUX. BOXES)
 RTD AUX. BOX
 SPACE HEATER AUX. BOX
 BEARING RTD's

TOSHIBA
 TOSHIBA INTERNATIONAL CORPORATION

TOTALLY-ENCLOSED FAN-COOLED
 HORIZONTAL FOOT-MOUNTED
 3 PHASE INDUCTION MOTOR
 F1 ASSEMBLY

XT SERIES
 VISIT OUR WEBSITE AT:
 www.toshiba.com/ind