

CLEARANCE REQUIRED TO REMOVE HOUSING

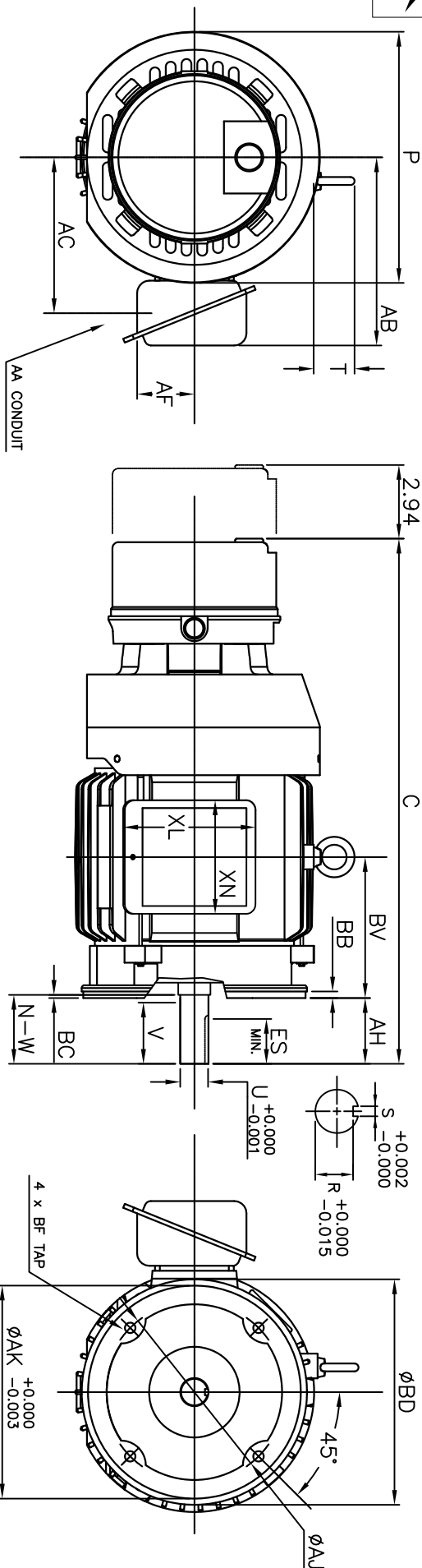

FRAME SIZE	FLANGE DIMENSIONS							
	AH	AJ	AK	BB	BC	BD	BF TAP	BV
182TC/184TC	2.62	7.250	8.500	0.25	0.13	6.94	1/2"-13UNC	5.63

UNITS: INCHES

FRAME SIZE	MOTOR DIMENSIONS											CONDUIT BOX						
	A	B	C	D	G	J	K	M	O	P	T	AA	AB	AC	AE	AF	XL	XN
182TC/184TC	-	-	21.0	-	-	-	-	-	-	10.1	2.0	0.75	7.7	6.3	-	2.3	5.3	4.6

FRAME SIZE	MOUNTING				SHAFT EXTENSION				KEY SEAT			BEARINGS			MAXIMUM WEIGHT
	E	ZF	H	BA	N-W	V	U	R	S	ES	LS	OS			
182TC/184TC	-	-	-	-	2.75	2.50	1.125	0.986	0.250	1.79	6207ZZ	6205ZZ	120 lbs.		

CUSTOMER: \_\_\_\_\_ MOTOR MODEL NO.: \_\_\_\_\_ TAG NO's: \_\_\_\_\_

P.O. NO.: \_\_\_\_\_ HP: \_\_\_\_\_ VOLTAGE: \_\_\_\_\_ RPM(SYN.): \_\_\_\_\_ Hz: \_\_\_\_\_  
 FRAME SIZE: \_\_\_\_\_ PRODUCT TYPE: ITEC EGP III, EPACT, & HIGH EFFICIENCY BRAKE SERIES  
 COMMENTS: 56,000 SERIES STEARNS BRAKE  
 \_\_\_\_\_  
 \_\_\_\_\_  
 PER: \_\_\_\_\_ DATE: \_\_\_\_\_

TOSHIBA RESERVES THE RIGHT TO MAKE CHANGES OF TECHNICAL IMPROVEMENT AND THE DATA MAY CHANGE WITHOUT NOTICE  PRELIMINARY  
 DO NOT USE FOR CONSTRUCTION, INSTALLATION, OR APPLICATION PURPOSES UNLESS THE DRAWING IS MARKED AS CERTIFIED  CERTIFIED

- NOTES:
1. DIMENSION V REPRESENTS LENGTH OF STRAIGHT PART OF SHAFT
  2. MAIN CONDUIT BOX MAY BE ROTATED IN 90° INCREMENTS
  3. KEY DIMENSIONS EQUAL S x S x 1.75 (MOTOR SUPPLIED WITH KEY)
  4. MOTOR WEIGHT SHOWN IS MAXIMUM HORSEPOWER IN FRAME
  5. STANDARD PRODUCT USE BI-DIRECTIONAL FAN. OPPOSITE ROTATION AVAILABLE ONLY BY CONNECTION CHANGE

STANDARD (NO AUX. BOXES)  
 RTD AUX. BOX  
 SPACE HEATER AUX. BOX  
 BEARING RTD's

**TOSHIBA**  
 TOSHIBA INTERNATIONAL CORPORATION  
 TOTALLY-ENCLOSED FAN-COOLED  
 ROUND-BODY  
 3 PHASE INDUCTION MOTOR  
 F1 ASSEMBLY

**XT SERIES**  
 VISIT OUR WEBSITE AT:  
 www.toshiba.com/ind