

100612

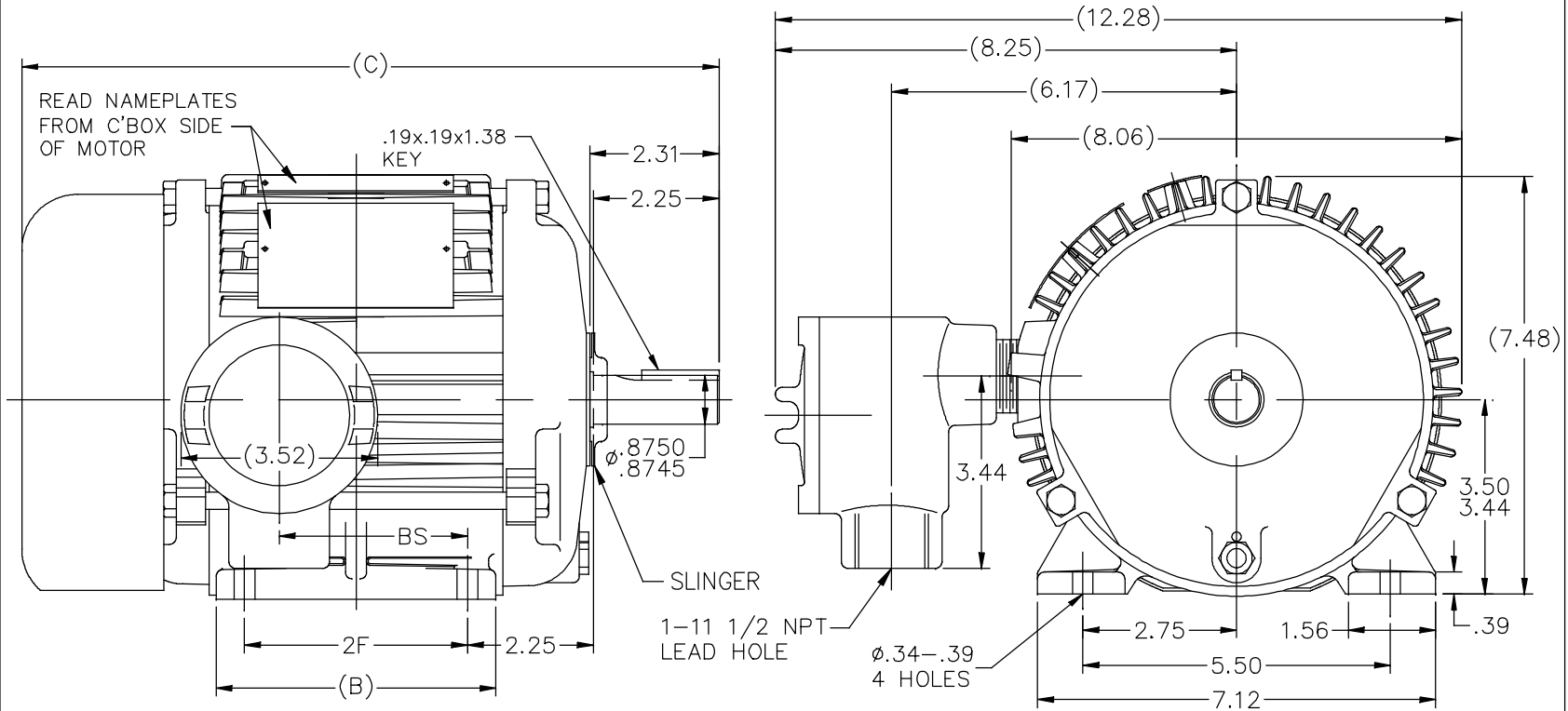

DASH	FR.	C	B	2F	BS
525	143	12.48	5.00	4.00	3.37
625	145	13.48	6.00	5.00	3.87

NOTE:
1. BOX CAN ONLY BE ROTATED CLOCKWISE UP TO 270° FROM ITS ORIGINAL POSITION.

NO.	REVISION	BY & DATE	CHK	ANG	TOLERANCES UNLESS SPECIFIED	DRAWN SMC 05-21-1992
6	ADDED SLINGER	SG 02/04/19	UD			APPD JA 05-29-1992
5	REDRAWN IN AUTOCAD	TAT 06-29-2004	ML	.X	±.1	SCALE 3=8
4	ADDED DRAIN PLUG TO REAR BRACKET CN 26916	DRS 01-11-1999		.XX	±.03	REF
3	ADDED 'BS' DIMENSION	MRB 04-25-1996		.XXX	±.005	FMF
2	REVISED NOTE CN 14695	RM 10-14-1992		.XXXX	±.0005	PREV
THIS DRAWING IN DESIGN AND DETAIL IS OUR PROPERTY AND MUST NOT BE USED EXCEPT IN CONNECTION WITH OUR WORK ALL RIGHTS OF DESIGN AND INVENTION ARE RESERVED THIS IS AN ELECTRONICALLY GENERATED DOCUMENT - DO NOT SCALE THIS PRINT						TITLE OUTLINE 140 FR.-BB-EXP.PR.-TS (629 NEW DESIGN)
CAD FILE 100612						SIZE A DRAWING NO. 100612 PAGE OF 6 REV. 6

