

CLEARANCE REQUIRED TO REMOVE HOUSING

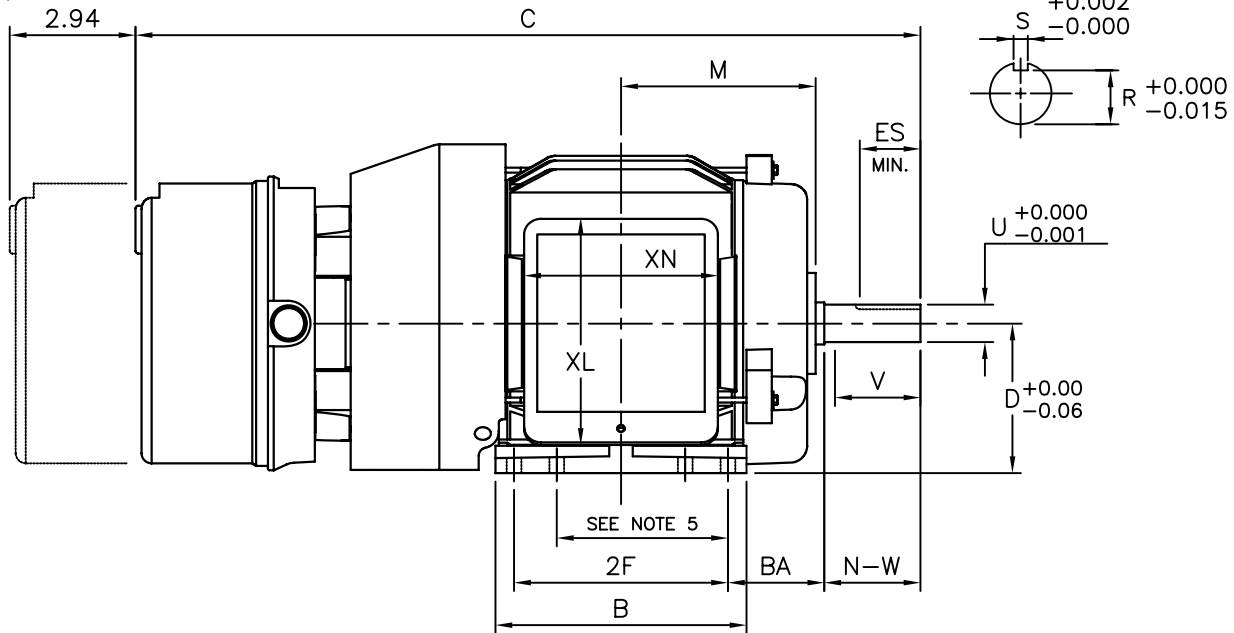

UNITS: INCHES

FRAME SIZE	MOTOR DIMENSIONS											CONDUIT BOX						
	A	B	C	D	G	J	K	M	O	P	T	AA	AB	AC	AE	AF	XL	XN
143T/145T	6.9	5.9	18.4	3.50	0.35	1.6	0	4.5	7.7	8.4	0	0.75	7.1	5.7	3.5	2.3	5.3	4.6

FRAME SIZE	MOUNTING			SHAFT EXTENSION				KEY SEAT			BEARINGS		MAXIMUM WEIGHT
	E	2F	H	BA	N-W	V	U	R	S	ES	LS	OS	
143T/145T	2.75	4.00/5.00	0.34	2.25	2.25	2.00	0.875	0.771	0.188	1.41	6205ZZ	6205ZZ	80 lbs.

NOTES:

1. DIMENSION V REPRESENTS LENGTH OF STRAIGHT PART OF SHAFT
2. MAIN CONDUIT BOX MAY BE ROTATED IN 90° INCREMENTS
3. KEY DIMENSIONS EQUAL S x S x 1.38 (MOTOR SUPPLIED WITH KEY)
4. MOTOR WEIGHT SHOWN IS MAXIMUM HORSEPOWER IN FRAME
5. THIS DIMENSION EQUALS 2F FOR 143T MOUNTING
6. STANDARD PRODUCT USE BI-DIRECTIONAL FAN. OPPOSITE ROTATION AVAILABLE ONLY BY CONNECTION CHANGE

CUSTOMER: \_\_\_\_\_ MOTOR MODEL NO.: **B1/262LF2OMH**  
 P.O. NO.: \_\_\_\_\_ HP: **0.5** VOLTAGE: **575** RPM(SYN.): **1200** Hz: **60**  
 FRAME SIZE: **143T** PRODUCT TYPE: **TEFC EQP III, EPACKT, & HIGH EFFICIENCY BRAKE SERIES**  
 COMMENTS: **56,000 SERIES STEARNS BRAKE**

TAG NO's: \_\_\_\_\_

<input checked="" type="checkbox"/>	STANDARD (NO AUX. BOXES)
<input type="checkbox"/>	RTD AUX. BOX
<input type="checkbox"/>	SPACE HEATER AUX. BOX
<input type="checkbox"/>	BEARING RTD's

PER: \_\_\_\_\_ DATE: \_\_\_\_\_

TOSHIBA RESERVES THE RIGHT TO MAKE CHANGES OF TECHNICAL IMPROVEMENT AND THE DATA MAY CHANGE WITHOUT NOTICE  PRELIMINARY

DO NOT USE FOR CONSTRUCTION, INSTALLATION, OR APPLICATION PURPOSES UNLESS THE DRAWING IS MARKED AS CERTIFIED  CERTIFIED

**TOSHIBA**

TOSHIBA INTERNATIONAL CORPORATION

TOTALLY-ENCLOSED FAN-COOLED  
 HORIZONTAL FOOT-MOUNTED  
 3 PHASE INDUCTION MOTOR  
 F1 ASSEMBLY

**XT SERIES**

VISIT OUR WEBSITE AT:  
[www.toshiba.com/ind](http://www.toshiba.com/ind)