

REV	ECO	REV BY	DATE	APPD	DATE
B	0025340	D.ZHANG	04-16-2012	B.SHEN	04-16-2012

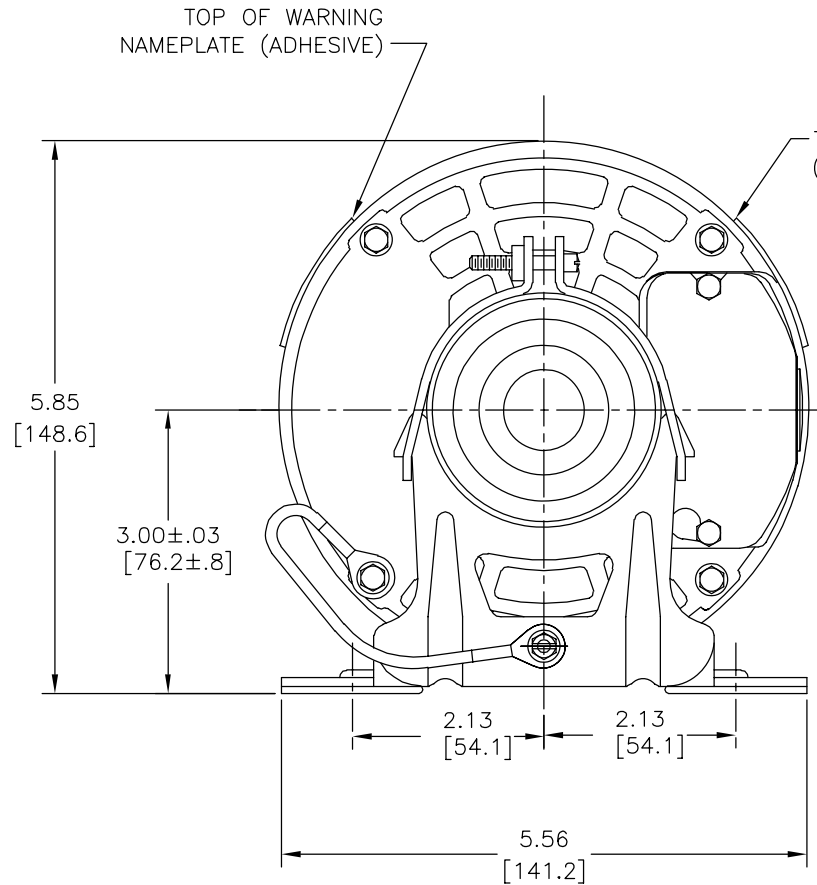

1/2-14 PIPE TAP FOR CONDUIT CONNECTION (PLUGGED)

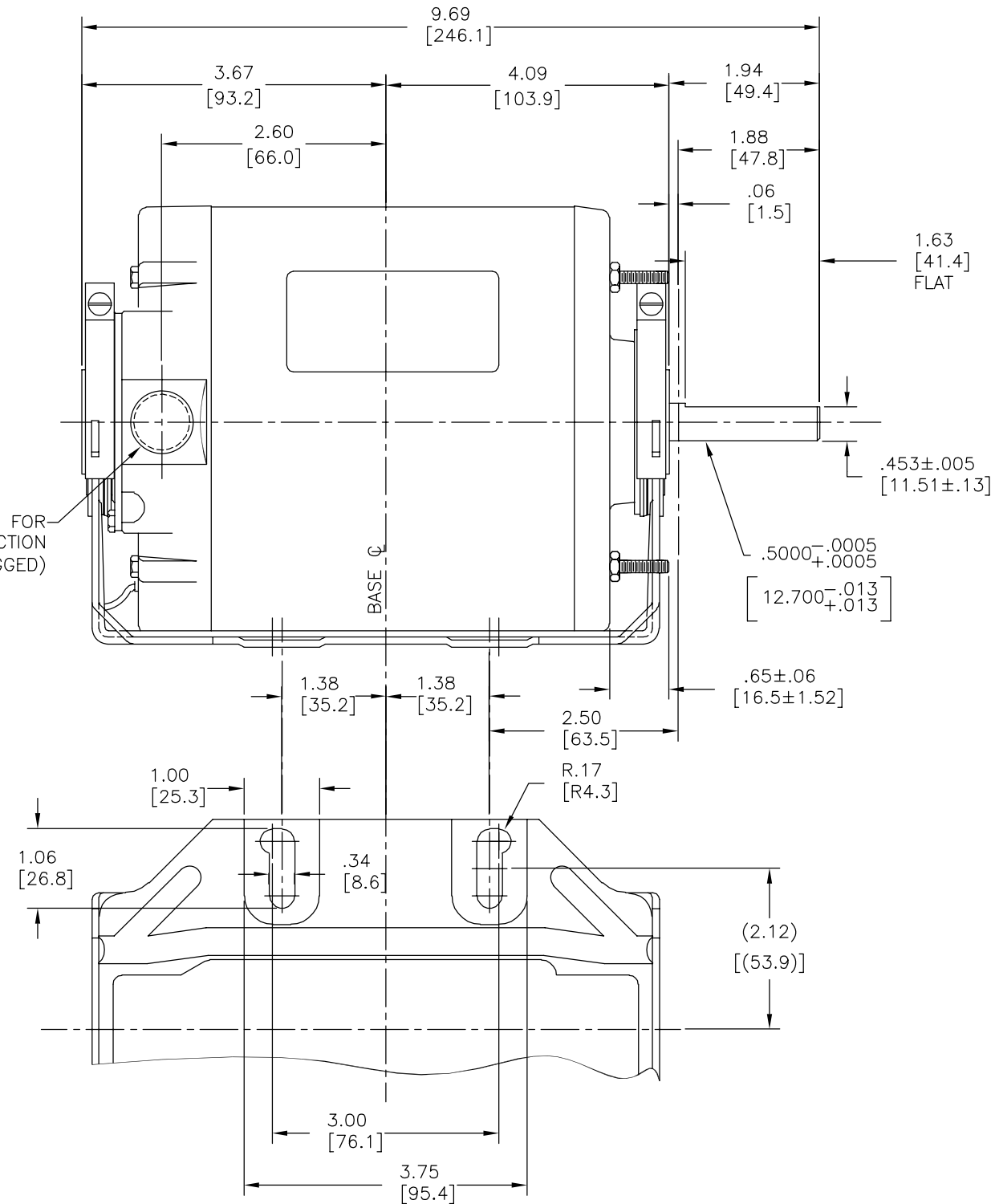

NOTES:
 ALL DIMENSIONS SHOWN IN PARENTHESIS ARE REFERENCE DIMENSIONS. ALL OTHER DIMENSIONS ARE TOLERANCED PER THE FOLLOWING CHART UNLESS OTHERWISE SPECIFIED.

OVERALL DIMENSION = +/- .055 [1.40]
 SHAFT EXTENSION = +/- .034 [.86]
 LEAD LENGTHS = +/- 1.00 [25.4]
 EXTENDED THRU-BOLTS = +/- .050 [1.27]
 ANGULAR DIMENSIONS = +/- 2'

GEOMETRIC CHARACTERISTICS & SYMBOLS	
▭	FLATNESS
—	STRAIGHTNESS
∠	ANGULARITY
⊥	PERPENDICULARITY (SQUARENESS)
//	PARALLELISM
○	ROUNDNESS (CIRCULARITY)
⊘	CYLINDRICITY
△	PROFILE OF ANY SURFACE
∧	PROFILE OF ANY LINE
↗	RUNOUT
⊕	TRUE POSITION
◎	CONCENTRICITY
≡	SYMMETRY
ASME Y14.5M 1994	

UNLESS OTHERWISE SPECIFIED DIM. TOLERANCES ARE AS FOLLOWS:	
INCH	±.1 ±.02 ±.005 ±.0005
mm	±0.5 ±0.13 ±0.013
ANG. ±.50 DEG	
REMOVE BURRS & BREAK SHARP EDGES:	
INCH	.003-.015
mm	0.1-0.4
CORNER FILLETS TO:	
INCH	.020
mm	0.5
MACHINE SURFACES:	
INCH	125
mm	3.2
METRIC DIMS. SHOWN IN [BRACKETS]	

DR BY:	JBLANK	07-01-2005
APPD:		
THIRD ANGLE PROJECTION	EDS DATE 11-11-2011	FORMAT REV G
CONFIDENTIAL: THIS DRAWING AND ITS INFORMATION ARE THE EXCLUSIVE AND CONFIDENTIAL PROPERTY OF REGAL-BELOIT CORPORATION AND ARE NOT TO BE DISCLOSED, DUPLICATED, DISTRIBUTED OR OTHERWISE USED WITHOUT THE WRITTEN CONSENT OF REGAL-BELOIT CORPORATION. -ALL RIGHTS RESERVED.		

DESCRIPTION	
OUTLINE	
SIZE	DWG NO
C	917L
SCALE	SHEET
NONE	1

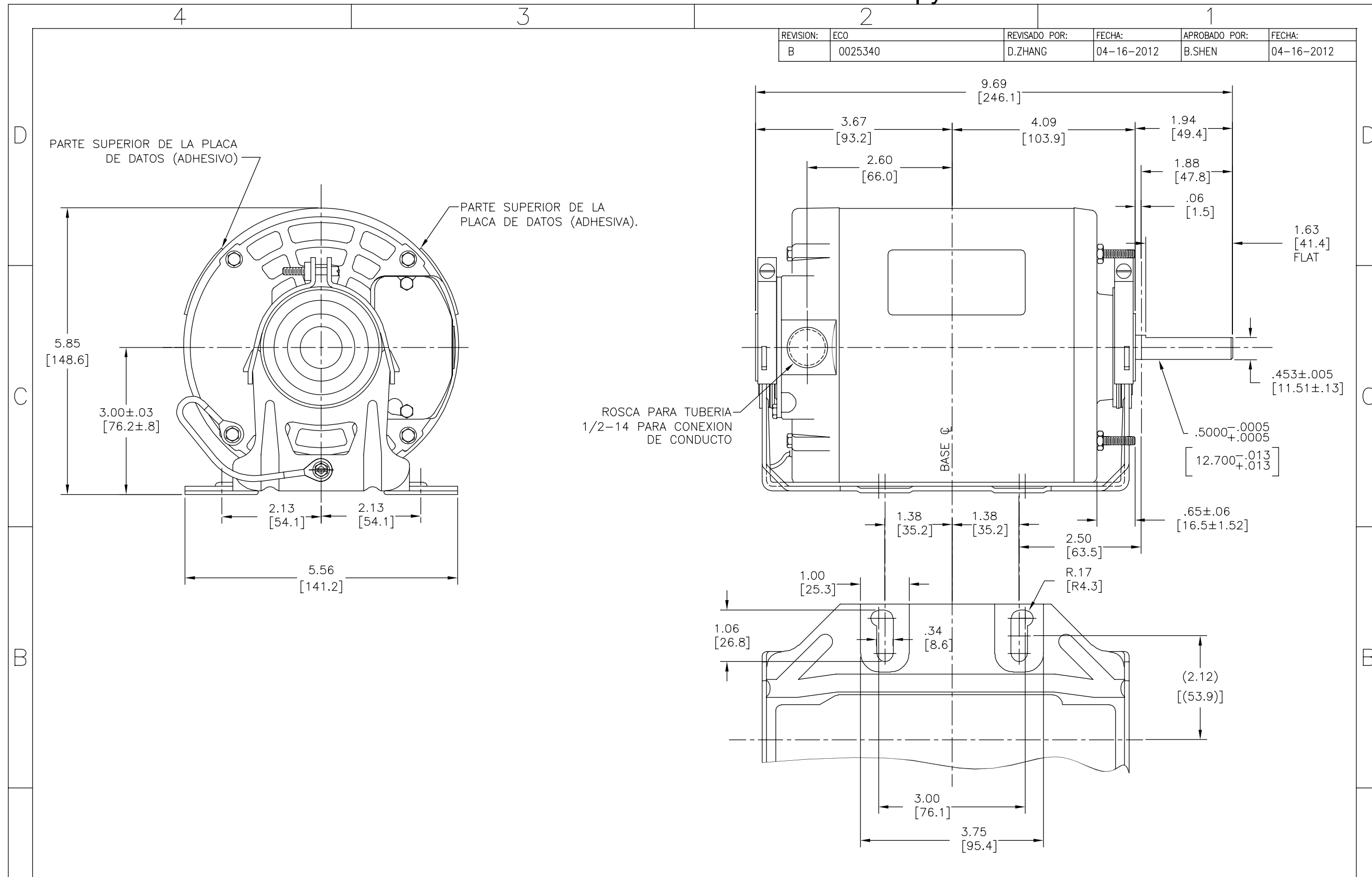

REVISION:	ECO	REVISADO POR:	FECHA:	APROBADO POR:	FECHA:
B	0025340	D.ZHANG	04-16-2012	B.SHEN	04-16-2012

CARACTERISTICAS DE GEOMETRIA Y SIMBOLOS
 □ PLANICIDAD
 - RECTITUD
 < ANGULARIDAD
 ⊥ PERPENDICULARIDAD (A ESCUADRA)
 // PARALELISMO
 ○ REDONDEZ (CIRCULARIDAD)
 ∅ CILINDRICIDAD
 △ PERFIL DE CUALQUIER SUPERFICIE
 ▲ PERFIL DE CUALQUIER LINEA
 / VARIACION
 ⊕ POSICION REAL
 ⊙ CONCENTRICIDAD
 = SIMETRIA

A MENOS QUE SE ESPECIFIQUE DE OTRA MANERA, LAS TOLERANCIAS DE LAS DIMS; SON LAS SIGUIENTES:
 PULG ±.1 ±.02 ±.005 ±.0005
 mm ±0.5 ±0.13 ±0.013
 ANG. ±50 GRADOS
 ELIMINAR REBABAS Y ORILLAS FILOSAS DEL BORDE.
 PULG .003-.015 mm 0.1-0.4
 FILETEAR ESQUINA: PULG .020 mm 0.5
 MAQUINAR SUPERFICIES
 PULG 125 mm 3.2

DIBUJADO POR: JBLANK 07-01-2005
 APROBADO POR:
 TERCER ANGULO DE PROYECCION
 FECHA EDS: 11-11-2011
 REV. FORMATO: G
 CONFIDENCIAL: ESTE DIBUJO Y SU INFORMACION SON PROPIEDAD DE USO EXCLUSIVO Y CONFIDENCIAL DE REGAL-BELOIT CORPORATION. Y NO DEBERAN SER REVELADOS, DUPLICADOS, DISTRIBUIDOS O USARSE DE OTRA MANERA SIN EL CONSENTIMIENTO ESCRITO DE REGAL-BELOIT CORPORATION. -TODOS LOS DERECHOS RESERVADOS.

REGAL-BELOIT CORPORATION
 DESCRIPCION: **OUTLINE**
 TAMAÑO: C NUMERO DE DIBUJO: 917L
 ESCALA: NONE HOJA: 1

4 3 2 1

版本	ECO	编制	日期	批准	日期
B	0025340	D.ZHANG	04-16-2012	B.SHEN	04-16-2012

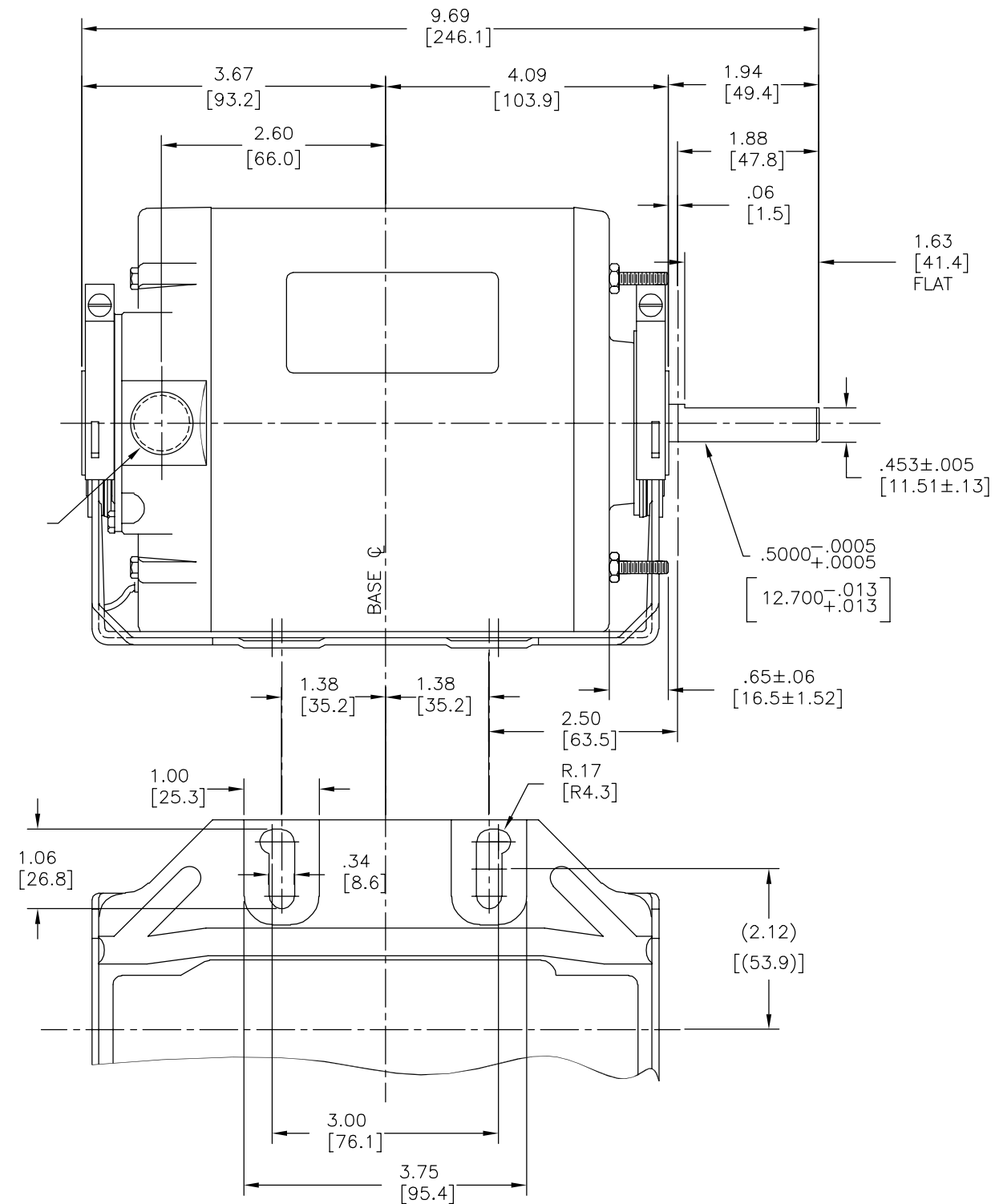
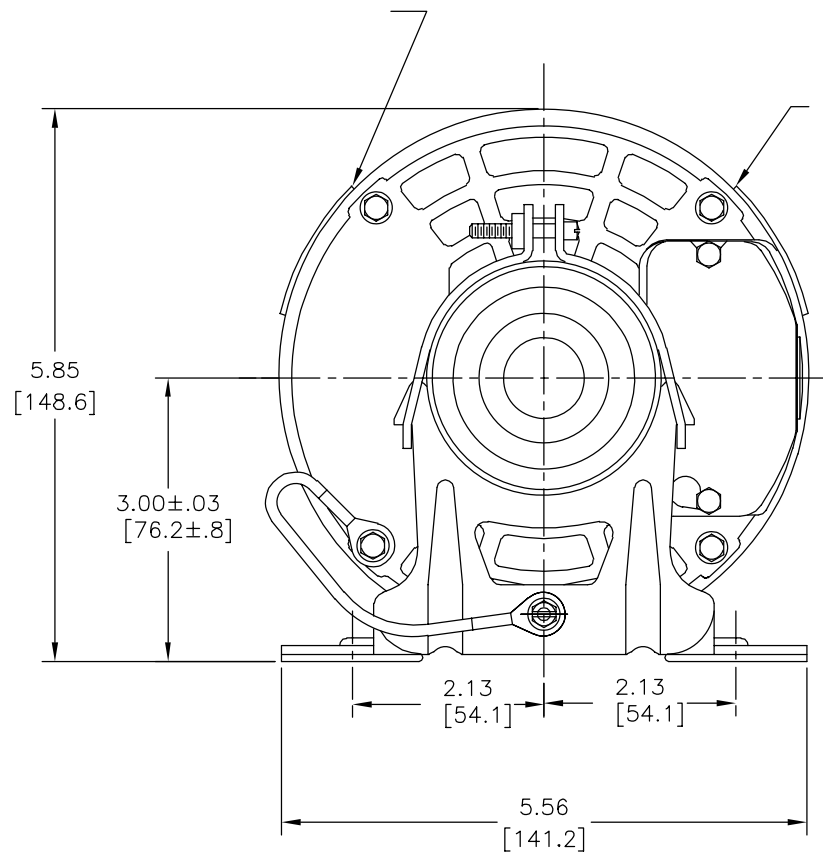

形位公差	除另有注明
□ 平面度	尺寸公差如下:
— 直线度	英寸 X XX XXX XXXX
∠ 倾斜度	英寸 ±.1 ±.02 ±.005 ±.0005
⊥ 垂直度	毫米 ±0.5 ±0.13 ±0.013
// 平行度	角度 ±.50 度
○ 圆度	清理毛刺和尖棱
⊘ 圆柱度	英寸 .003-.015 毫米 0.1-0.4
△ 面轮廓度	内圆角
∩ 线轮廓度	英寸 .020 毫米 0.5
⌒ 圆跳动	表面粗糙度
⊕ 位置度	英制 125 米制 3.2
⊙ 同轴度	米制尺寸显示在 []
≡ 对称度	

ASME Y14.5M 1994

绘图:	JBLANK	07-01-2005
批准:		
第三角投影		图纸格式发布日期 11-11-2011 图纸格式版本 G
机密: 本图纸及相关信息所有权归REGAL-BELOIT CORPORATION. 未经REGAL-BELOIT CORPORATION书面授权, 不得泄露、复制、传播或作其他用途。—版权所有		

名称	OUTLINE
图幅	C
图号	917L
比例	NONE
页号	1

4 3 2 1