

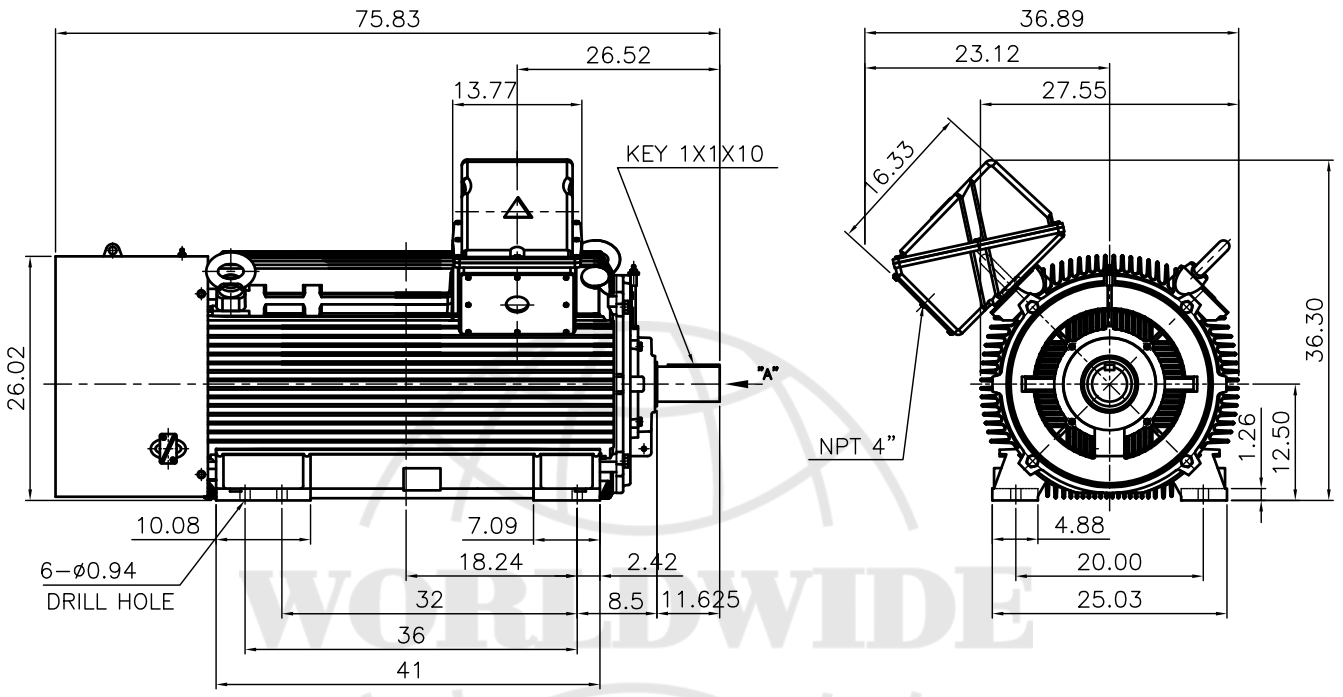

**TEFC**  
**THREE PHASE INDUCTION MOTOR**

**TYPE**

(1)  
L,J,LP,JP  
CAST IRON FRAME



**NOTE**

1.TOLERANCE :

CENTER HEIGHT	12.5	+0.000	-0.060
SHAFT DIAMETER	ø3.875	+0.000	-0.001
KEYWAY WIDTH	1	+0.003	-0.000

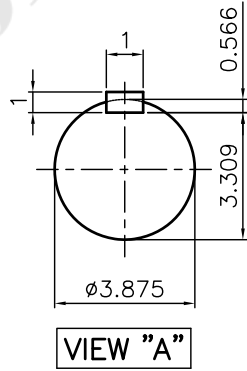

TEFC STANDARD

Q'TY	DESCRIPTION	MATERIAL	DIMENSION	WEIGHT	PART NO.	REMARK	NO.
APPD BY	강경중	UNIT	mm	SUBJECT	XL SERIES Fr.5010/5011-4~20P	DWG SIZE	A4 (1:21)
CHKD BY	김진홍	SCALE	1/21	TITLE	CAST IRON T-BOX		
CHKD BY	김옥진	PROJEC'N	3각법 (3rd Angle)	<b>Outline</b>			
DSND BY	김양규	DATE	2013-01-05				



REF. NO	Sheet No.	of
DWG NO	LM-T0511B3PL001	Revision No. 2