



TEFC

THREE PHASE INDUCTION MOTOR

TYPE

XKP

CAST IRON FRAME

FRAME SIZE

OUTPUT(HP)

POLES

Hz

TIME RATING

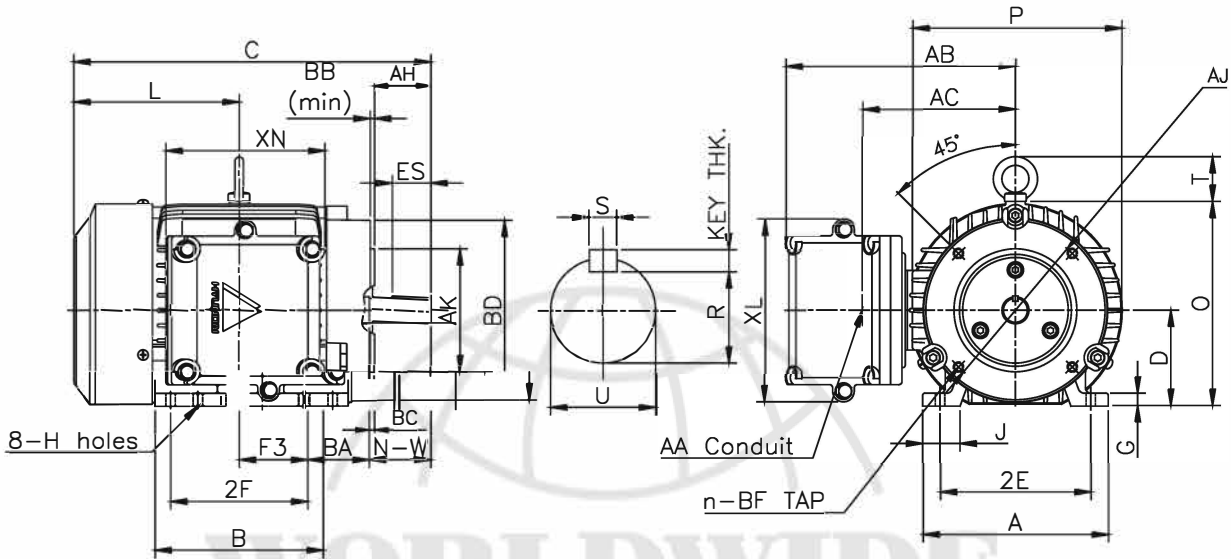

DIMENSIONS

FLANGE							MOUNTING									
AJ	AK	BD	BB	BC	BF	n	A	B	2E	2F	-	F3	G	J	H	
5.875	4.50	6.570	1.16	+0.12	3/8-16	4	6.78	6.15	5.50	5.00	-	2.50	0.45	1.36	0.34	

CONDUIT BOX						OVERALL							APPROX. WGT.(LB)
AA	AB	AC	XB	XL	XN	BA	C	D	L	O	P	T	
0.75	8.39	5.59	-	6.69	5.98	2.25	13.05	3.50	6.05	7.46	7.64	1.63	66

SHAFT						KEY THK.	BEARING	
U	N-W	A-H	KEYWAY				DRIVE END	OPP. DRIVE END
			R	ES	S			
0.875	2.25	2.12	0.771	1.41	0.188	0.188	6205ZZC3	6204ZZC3

NOTE

- 1.Dimension "D" tolerance : +0.00inch - 0.03inch
- 2.Dimension "U" tolerance : +0.000inch - 0.0005inch
- 3.Dimension "R" tolerance : +0.000inch - 0.015inch

APPD BY	J.H.KIM	UNIT	INCH	SUBJECT	NEMA 145TC(KIT)	CAD PROJ \ FILE
CHKD BY	N.D.LEE	SCALE	1/8			LM-U0145B3TL001
CHKD BY	K.S.LEE	PROJEC'N	3rd Angle	TITLE OUTLINE		
DSND BY	S.W.SEO	DATE	2012.02.11			



REF. NO	LM-U0145C4TL001	Sheet No.	of
DWG NO	LM-U0145C4TL001	Revision No.	0