

<p>HYUNDAI HEAVY INDUSTRIES CO., LTD.</p>	<h1 style="margin: 0;">TEFC</h1> <p style="margin: 0;">THREE PHASE INDUCTION MOTOR</p>	<p>TYPE</p>	<p>XKP,XIP</p> <hr/> <p>Cast iron frame</p>
--	---	--------------------	---

FRAME SIZE	OUTPUT(HP)	POLES	Hz	TIME RATING
405TSC			60	CONT

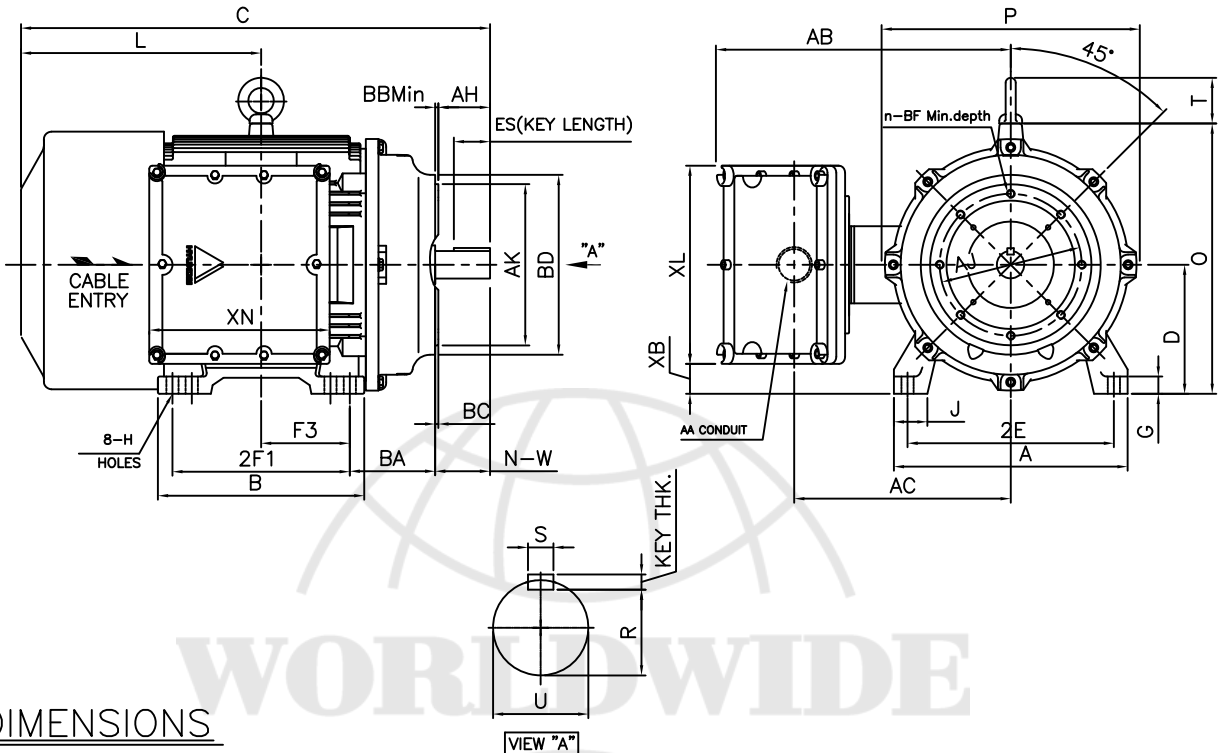

DIMENSIONS

MOUNTING									CONDUIT BOX						APPROX. WGT.(LB)
A	B	2E	2F1	2F2	F3	G	J	H	AA	AB	AC	XB	XL	XN	
18.11	15.98	16.00	13.75	-	6.870	1.18	2.59	0.81	3.00	22.83	17.32	2.16	15.35	13.97	2P: 1864 4P: 1852 6P: 1852

OVERALL						SHAFT				KEY THK.	BEARING			
BA	C	D	L	O	P	U	N-W	R	ES		S	DRIVE END	OPP. DRIVE END	
6.62	36.33	10.00	18.60	20.94	20.00	3.55	2.125	4.25	1.845	2.80	0.500	0.500	6313C3	6313C3

C - FACE								
AJ	AK	BB Min	BC	BD	BF	BF depth	n	AH
11.00	12.50	0.25	0.25	13.93	5/8-11	0.94	8	4.00

NOTE

- 1.Dimension "D" tolerance : +0.00inch ~ -0.03inch (143TC-365TC) : +0.000inch ~ -0.06inch (404TC-449TC)
- 2.Dimension "U" tolerance : +0.000inch ~ -0.0005inch (143TC-215TC): +0.000inch ~ -0.001inch (254TC-449TC)
- 3.Dimension "R" tolerance : +0.000inch ~ - 0.015inch
- 4.Dimension "AK" tolerance : +0.000inch ~ -0.003inch (143TC-286TC): +0.000inch ~ -0.005inch (324TC-449TC)

Q'TY	DESCRIPTION	MATERIAL	DIMENSION	WEIGHT	PART NO.	REMARK	NO.
		UNIT	mm	SUBJECT			DWG SIZE
		SCALE	1/15	405TSC			A4 (1:15)
		PROJEC'N	3각법(3rd Angle)	TITLE			
				Outline			
		DATE	2012-06-15				

HYUNDAI
HEAVY INDUSTRIES CO., LTD.

REF. NO	Sheet No. of
DWG NO	Revision No. 0