



TEFC

THREE PHASE INDUCTION MOTOR

TYPE

LP,JP

CAST IRON FRAME

FRAME SIZE

OUTPUT(HP)

POLES

Hz

TIME RATING

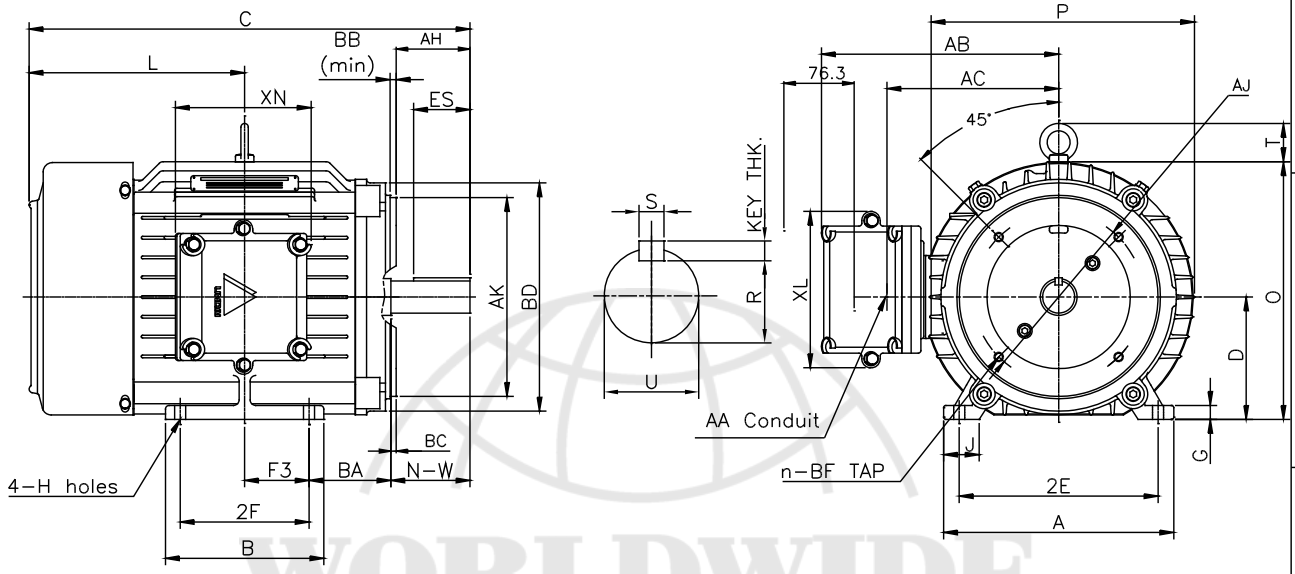

DIMENSIONS

FLANGE							MOUNTING								
AJ	AK	BD	BB	BC	BF	n	A	B	2E	2F	-	F3	G	J	H
7.25	8.50	9.00	0.25	+0.25	1/2-13	4	9.85	6.77	8.50	5.50	-	2.75	0.60	1.52	0.41

CONDUIT BOX							OVERALL						APPROX. WGT.(LB)
AA	AB	AC	XB	XL	XN	BA	C	D	L	O	P	T	
1.00	10.15	7.35	-	6.70	5.98	3.50	18.86	5.25	9.22	11.02	11.26	1.63	160

SHAFT						KEY THK.	BEARING	
U	N-W	A-H	KEYWAY				DRIVE END	OPP. DRIVE END
			R	ES	S			
1.375	3.38	3.12	1.201	2.41	0.312	0.312	6307ZZC3	6307ZZC3

NOTE

- 1.Dimension "D" tolerance : +0.00inch - 0.03inch
- 2.Dimension "U" tolerance : +0.000inch - 0.0005inch
- 3.Dimension "R" tolerance : +0.000inch - 0.015inch

APPD BY	J.H.KIM	UNIT	INCH	SUBJECT	NEMA 213TC(KIT)	CAD PROJ \ FILE
CHKD BY	N.D.LEE	SCALE	1/8			TITLE
CHKD BY	K.S.LEE	PROJEC'N	3rd Angle	<h1>OUTLINE</h1>		
DSND BY	S.W.SEO	DATE	2012.02.11			

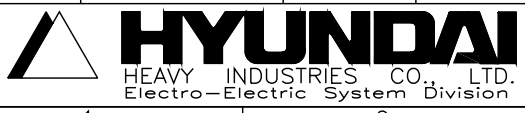

REF. NO	LM-U0213C4TL001	Sheet No.	of
DWG NO	LM-U0213C4TL001	Revision No.	0