

본 도면은 현대중공업(주) 재산이므로  
허가없이 복사할 수 없음 (취급유의)

THIS DRAWING IS PROPRIETARY TO HHI. NO PART OF THIS DRAWING  
MAYBE REPRODUCED WITHOUT THE PERMISSION OF HHI.

		<b>TEFC</b>		<b>TYPE</b>	XKP,XIP
		<b>THREE PHASE INDUCTION MOTOR</b>			Cast iron frame

FRAME SIZE	OUTPUT(HP)	POLES	Hz	TIME RATING
447TS			60	CONT

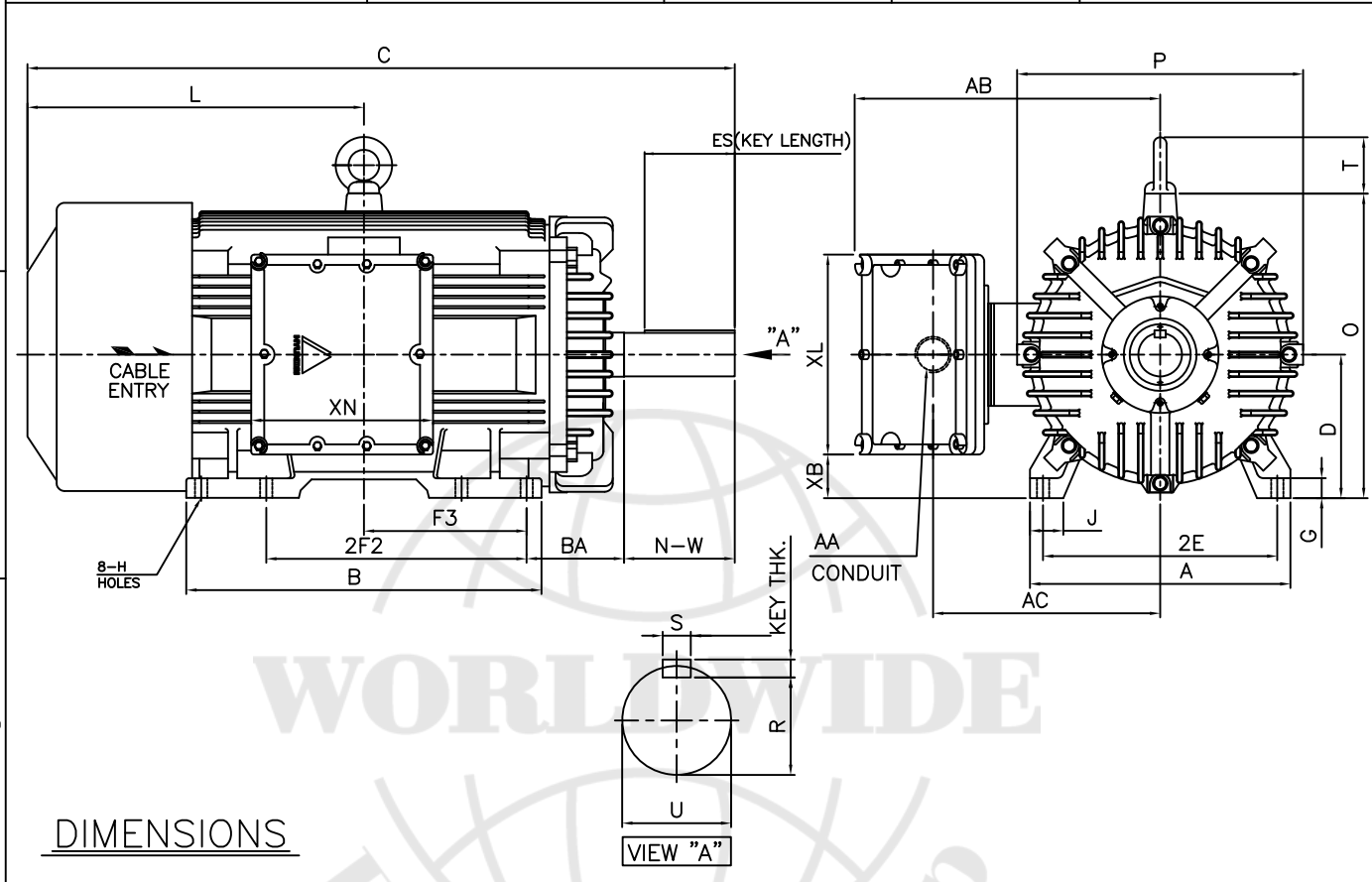

DIMENSIONS

MOUNTING									CONDUIT BOX						APPROX. WGT.(LB)
A	B	2E	2F1	2F2	F3	G	J	H	AA	AB	AC	XB	XL	XN	
20.00	27.28	18.00	-	20.00	12.50	1.53	2.56	0.81	3.00	24.01	18.30	3.34	15.35	13.97	2P: 2690 or 3020 4P: 2756 or 3086 6P: 2756 or 3086

OVERALL									SHAFT			KEY THK.	BEARING	
BA	C	D	L	O	P	T	U	N-W	KEYWAY				DRIVE END	OPP. DRIVE END
									R	ES	S			
7.50	50.57	11.00	25.84	23.38	21.97	4.33	2.375	4.75	2.021	3.03	0.625	0.625	6314C3	6314C3

NOTE

- Dimension "D" tolerance : +0.00inch - 0.03inch (143T-365T) ; +0.000inch - 0.06inch (404T-449T)
- Dimension "U" tolerance : +0.000inch - 0.005inch (143T-215T), +0.000inch - 0.001inch (254T-449T)
- Dimension "R" tolerance : +0.000inch - 0.015inch

Q'TY	DESCRIPTION	MATERIAL	DIMENSION	WEIGHT	PART NO.	REMARK	NO.
APPD BY		UNIT	mm	SUBJECT	449TS	DWG SIZE	
CHKD BY		SCALE	1/15	TITLE	Outline		
CHKD BY		PROJEC'N	3각법(3rd Angle)				
DSND BY	김중선	DATE	2012-04-09				