



# TEFC

**THREE PHASE INDUCTION MOTOR**

**TYPE**

XLP, XJP

CAST IRON FRAME

FRAME SIZE

OUTPUT(HP)

POLES

Hz

TIME RATING

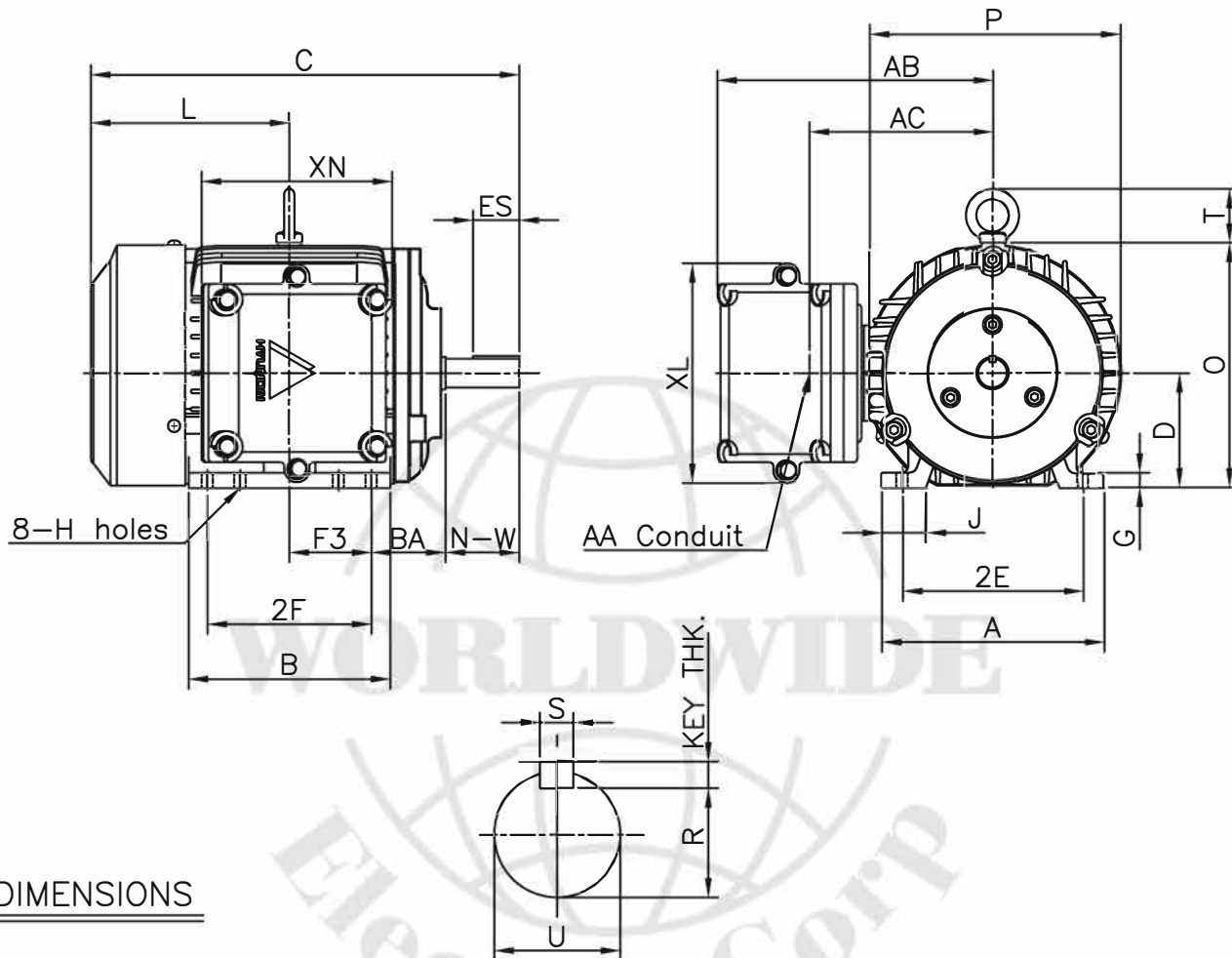

DIMENSIONS

M O U N T I N G									C O N D U I T B O X						APPROX. WGT.(lb)
A	B	2E	2F	-	F3	G	J	H	AA	AB	AC	XB	XL	XN	
6.78	6.15	5.50	4.00	-	2.50	0.47	1.36	0.34	0.75	8.39	5.59	-	6.69	5.98	66

O V E R A L L							S H A F T					KEY THK.	B E A R I N G	
BA	C	D	L	O	P	T	U	N-W	KEYWAY				DRIVE END	OPP. DRIVE END
									R	ES	S			
2.25	13.05	3.50	6.05	7.46	7.64	1.63	0.875	2.25	0.771	1.41	0.188	0.188	6205ZZC3	6204ZZC3

**NOTE**

- 1.Dimension "D" tolerance : +0.00inch - 0.03inch
- 2.Dimension "U" tolerance : +0.000inch - 0.0005inch
- 3.Dimension "R" tolerance : +0.000inch - 0.015inch

APPD BY	J.H.KIM	UNIT	INCH	SUBJECT	NEMA 145T	CAD PROJ \ FILE	LM-U1145B3TL001			
CHKD BY	N.D.LEE	SCALE	1/8			TITLE	OUTLINE	REF. NO	LM-U1145B3TL001	Sheet No. of
CHKD BY	K.S.LEE	PROJEC'N	3rd Angle	DSND BY	S.W.SEO	DATE		2012.02.11	DWG NO	LM-U1145B3TL001

