

본 도면은 현대중공업(주) 재산이므로
허가없이 복사할 수 없음 (취급유의)

THIS DRAWING IS PROPRIETARY TO HHI. NO PART OF THIS DRAWING
MAYBE REPRODUCED WITHOUT THE PERMISSION OF HHI.

		<h1>TEFC</h1>		<h2>TYPE</h2>		XKP,XIP	
		<h3>THREE PHASE INDUCTION MOTOR</h3>				Cast iron frame	

FRAME SIZE	OUTPUT(HP)	POLES	Hz	TIME RATING
449T			60	CONT

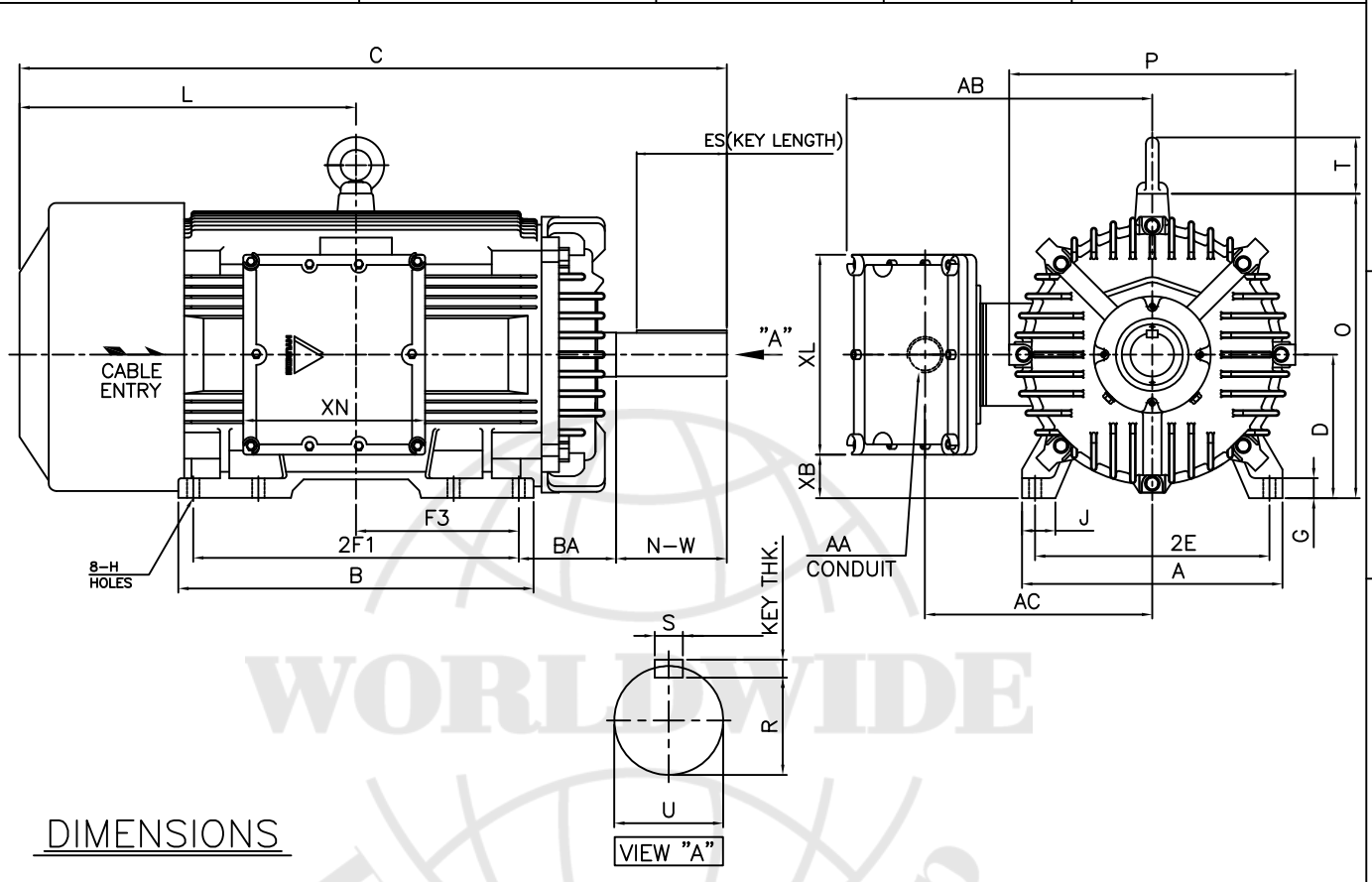

DIMENSIONS

MOUNTING									CONDUIT BOX					APPROX. WGT.(LB)
A	B	2E	2F1	2F2	F3	G	J	H	AA	AB	AC	XB	XL	
20.00	27.28	18.00	25.00	-	12.50	1.53	2.56	0.81	3.00	24.01	18.30	3.34	15.35	13.97

OVERALL								SHAFT			KEY	BEARING		
BA	C	D	L	O	P	T	U	N-W	KEYWAY			THK.	DRIVE END	OPP. DRIVE END
									R	ES	S			
7.50	54.32	11.00	25.84	23.38	21.97	4.33	3.375	8.50	2.880	6.93	0.875	0.875	6320C3 or NU320	6318C3

NOTE

1. Dimension "D" tolerance : +0.00inch - 0.03inch (143T-365T) ; +0.000inch - 0.06inch (404T-449T)
2. Dimension "U" tolerance : +0.000inch - 0.005inch (143T-215T), +0.000inch - 0.001inch (254T-449T)
3. Dimension "R" tolerance : +0.000inch - 0.015inch

Q'TY	DESCRIPTION	MATERIAL	DIMENSION	WEIGHT	PART NO.	REMARK	NO.
APPD BY		UNIT	mm	SUBJECT	449T	DWG SIZE	
CHKD BY		SCALE	1/15	TITLE	Outline		
CHKD BY		PROJEC'N	3각법(3rd Angle)				
DSND BY	김중선	DATE	2012-02-16				