



TEFC

THREE PHASE INDUCTION MOTOR

TYPE

XLP, XJP

CAST IRON FRAME

FRAME SIZE

OUTPUT(HP)

POLES

Hz

TIME RATING

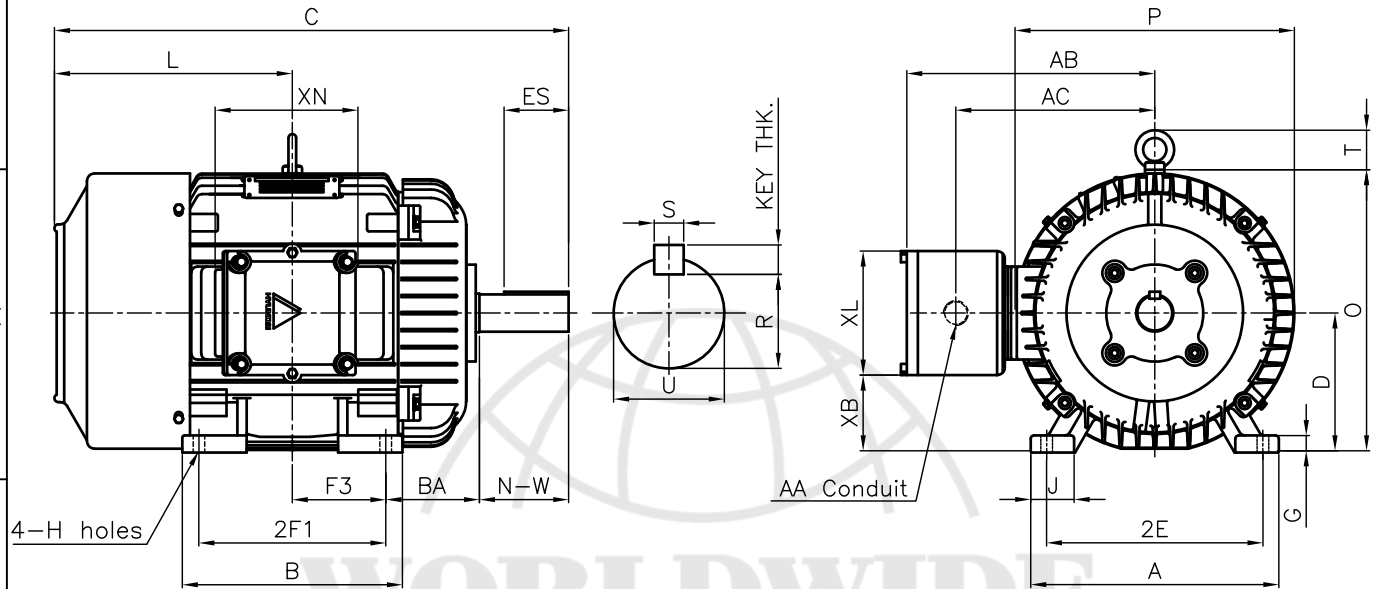

DIMENSIONS

M O U N T I N G									C O N D U I T B O X						APPROX. WGT.(LB)
A	B	2E	2F1	2F2	F3	G	J	H	AA	AB	AC	XB	XL	XN	284T
12.60	11.18	11.00	9.50	-	4.75	0.78	2.20	0.53	1.50	12.60	10.10	3.94	6.30	7.32	440

O V E R A L L							S H A F T					KEY THK.	B E A R I N G	
BA	C	D	L	O	P	T	U	N-W	KEYWAY				DRIVE END	OPP. DRIVE END
									R	ES	S			
4.75	26.21	7.00	12.09	14.28	14.19	2.01	1.875	4.62	1.591	3.28	0.500	0.500	6310ZC3	6310ZC3

NOTE

- 1.Dimension "D" tolerance : +0.00inch - 0.03inch
- 2.Dimension "U" tolerance : +0.000inch - 0.001inch
- 3.Dimension "R" tolerance : +0.000inch - 0.015inch

APPD BY	J. H. KIM	UNIT	INCH	SUBJECT	NEMA 284T	CAD PROJ \ FILE	XSMOUTIN\A1109AA	
CHKD BY	K. S. LEE	SCALE	1/10					
CHKD BY		PROJEC'N	3rd Angle	TITLE				OUTLINE
DSND BY	KIM IN KYU	DATE	2010.12.31					

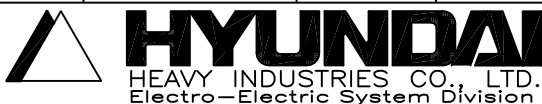

REF. NO	A1109AA	Sheet No.	of
DWG NO	LM-U1284B3TL001	Revision No.	0