



IEEE841 TEFC

THREE PHASE INDUCTION MOTOR

TYPE

PLP

CAST IRON FRAME

FRAME SIZE

OUTPUT(HP)

POLES

Hz

TIME RATING

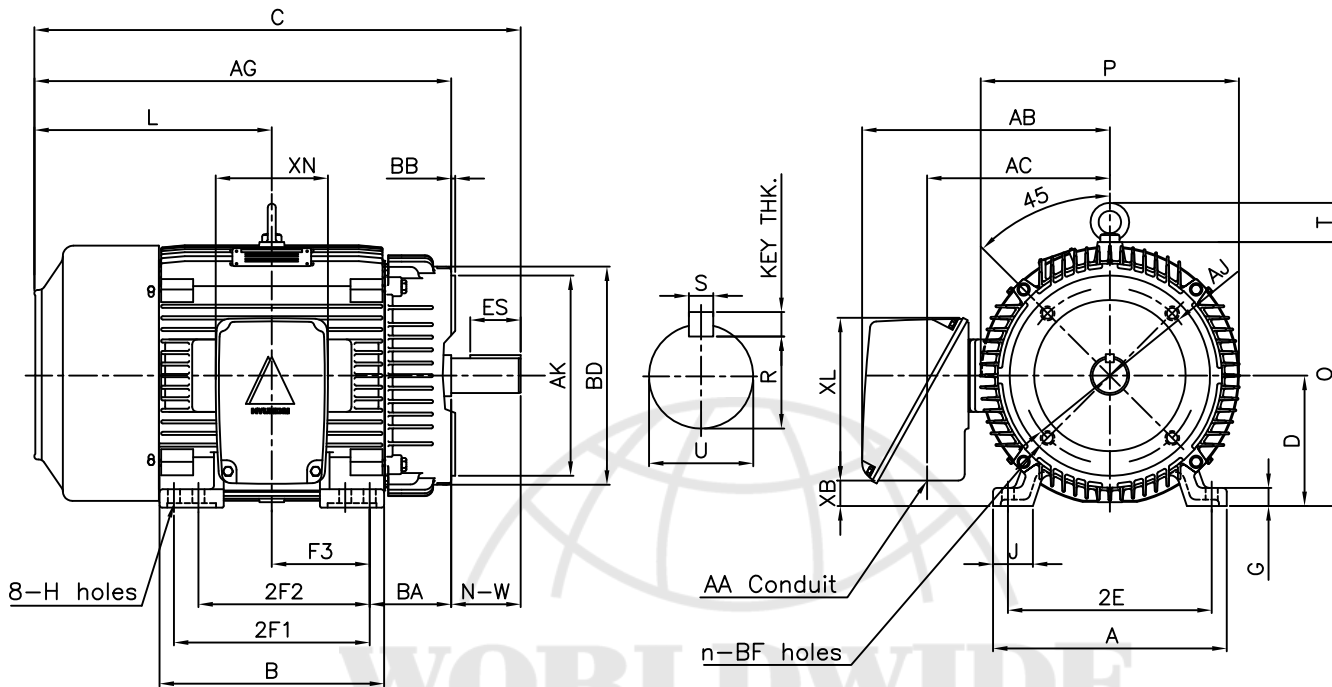

F L A N G E						M O U N T I N G								
AJ	AK	BD	BB	BF	n	A	B	2E	2F1 ⁵⁾	2F2 ⁴⁾	F3	G	J	H
11.0	12.50	13.27	0.25	5/8-11	4	14.33	13.78	12.50	12.00	10.50	6.00	1.11	2.44	0.66

C O N D U I T B O X						O V E R A L L								A P P R O X . W G T . (L B)	
AA	AB	AC	XB	XL	XN	AG	BA	C	D	L	O	P	T	324TS	326TS
2.00	15.20	11.21	1.57	10.16	7.01	25.82	5.25	29.60	8.00	14.60	16.19	15.84	2.41	530	540

S H A F T					KEY THK.	B E A R I N G	
U	N-W	KEYWAY				DRIVE END	OPP. DRIVE END
		R	ES	S			
1.75	3.75	1.591	2.03	0.500	0.500	6313ZC3	6211ZC3

NOTE

- 1.Dimension "D" tolerance : +0.00inch - 0.03inch
- 2.Dimension "U" tolerance : +0.000inch - 0.001inch
- 3.Dimension "R" tolerance : +0.000inch - 0.015inch
- 4.Location of holes for 324TSC frame
- 5.Location of holes for 326TSC frame

APPD BY	KIM.Y.S	UNIT	INCH	SUBJECT	NEMA 324TSC/326TSC	CAD PROJ \ FILE
CHKD BY	KO.S.H	SCALE	1/12	TITLE	OUTLINE	XSMOUTN\A8312BA
CHKD BY		PROJEC'N	3rd Angle			
DSND BY	LEE KWANG SOO	DATE	2004.04.02			



REF. NO	A1312BA	Sheet No.	of
DWG NO	350A8312BA	Revision No.	0