



1 E E E 8 4 1 TEFC

**THREE PHASE INDUCTION MOTOR**

**TYPE**

LP,JP

CAST IRON FRAME

FRAME SIZE

OUTPUT(HP)

POLES

Hz

TIME RATING

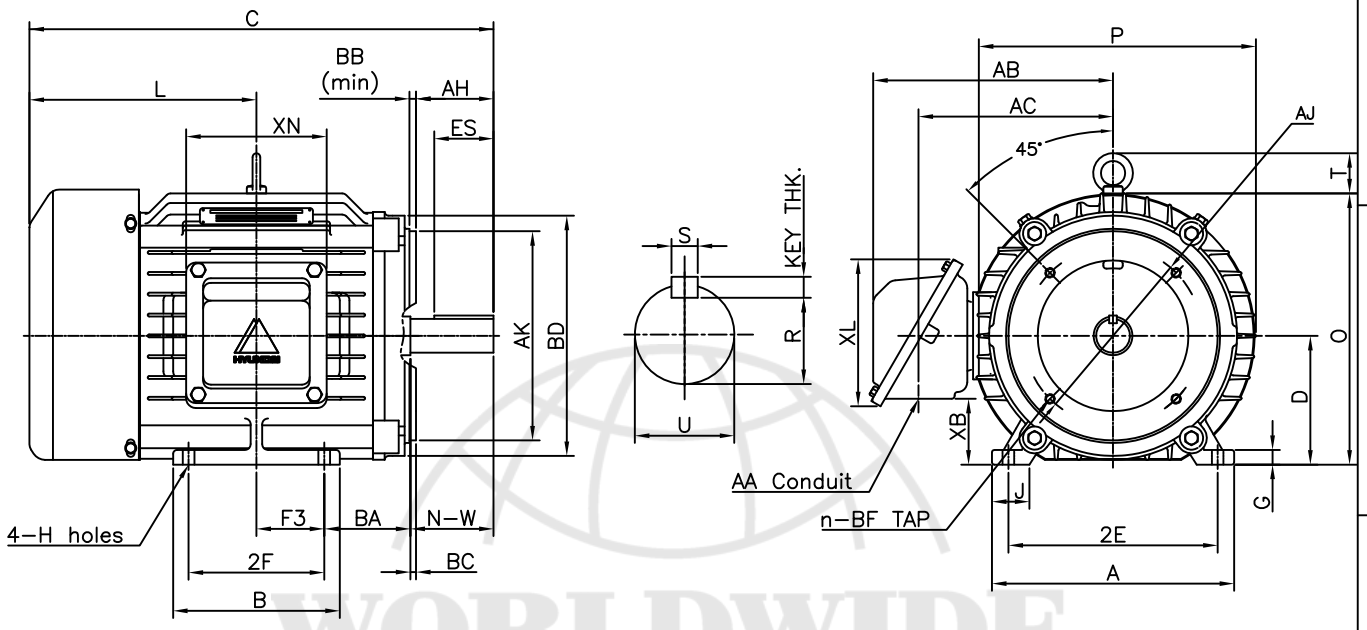

DIMENSIONS

F L A N G E							M O U N T I N G									
AJ	AK	BD	BB	BC	BF	n	A	B	2E	2F	-	F3	G	J	H	
7.25	8.50	9.00	0.25	+0.25	1/2-13	4	9.85	6.77	8.50	5.50	-	2.75	0.60	1.52	0.41	

C O N D U I T B O X						O V E R A L L							APPROX. WGT.(LB)
AA	AB	AC	XB	XL	XN	BA	C	D	L	O	P	T	
1.00	9.82	7.90	2.67	5.97	5.71	3.50	18.86	5.25	9.22	11.02	11.26	1.63	150

S H A F T						KEY THK.	B E A R I N G	
U	N-W	A-H	K E Y W A Y				D R I V E E N D	O P P. D R I V E E N D
			R	ES	S			
1.375	3.38	3.12	1.201	2.41	0.312	0.312	6307ZZC3	6307ZZC3

**NOTE**

- 1.Dimension "D" tolerance : +0.00inch - 0.03inch
- 2.Dimension "U" tolerance : +0.000inch - 0.0005inch
- 3.Dimension "R" tolerance : +0.000inch - 0.015inch

APPD BY	J.H.KIM	UNIT	INCH	SUBJECT	NEMA 213TC(KIT)	CAD PROJ \ FILE
CHKD BY	N.D.LEE	SCALE	1/8			SCALE-NEMA\A1305AA
CHKD BY	K.S.LEE	PROJEC'N	3rd Angle	TITLE <b>OUTLINE</b>		
DSND BY	S.W.SEO	DATE	2010.12.20			

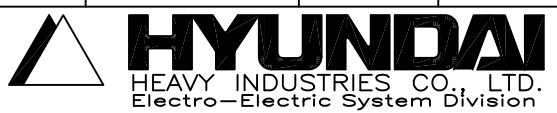

REF. NO	350A8305AA	Sheet No.	of
DWG NO	350A8305AA	Revision No.	0