



IEEE 841 TEFC

THREE PHASE INDUCTION MOTOR

TYPE

PLP
CAST IRON FRAME

FRAME SIZE	OUTPUT(HP)	POLES	Hz	TIME RATING

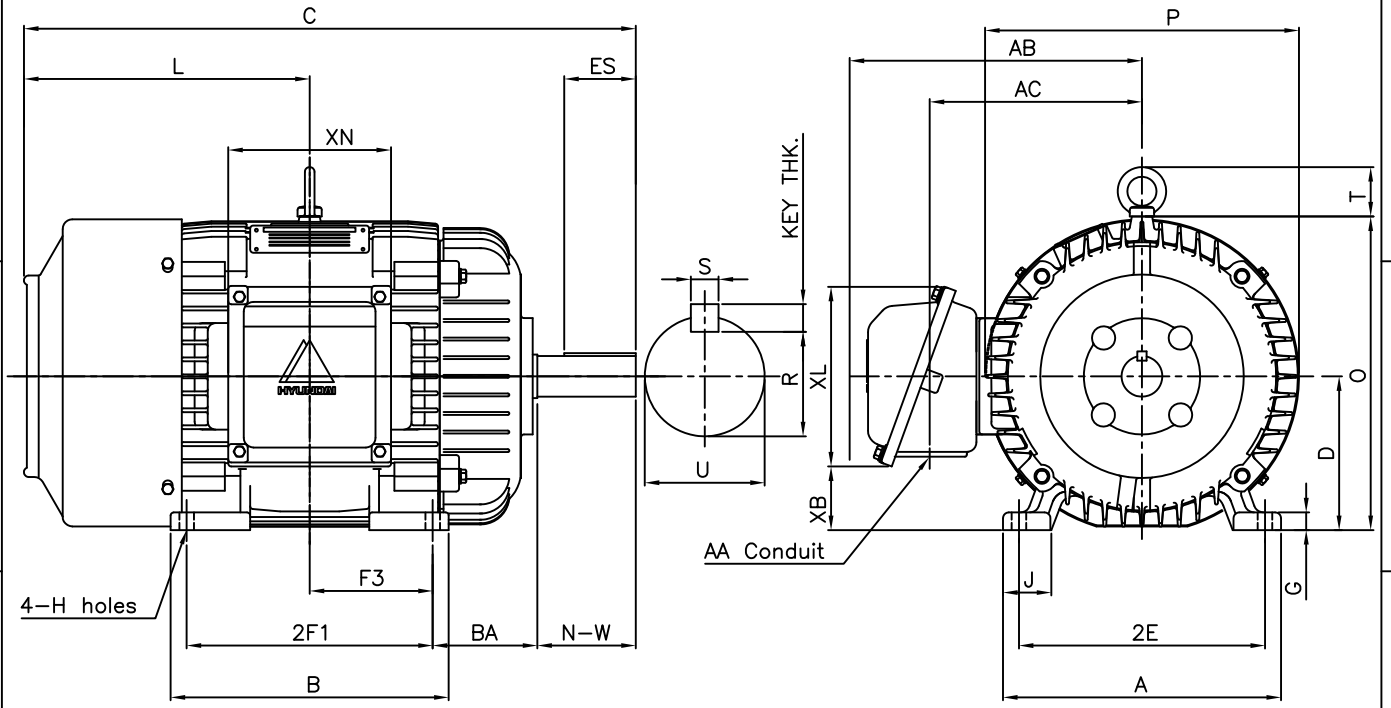

DIMENSIONS

MOUNTING									CONDUIT BOX						APPROX. WGT.(LB)
A	B	2E	2F1	2F2	F3	G	J	H	AA	AB	AC	XB	XL	XN	
11.30	11.30	10.00	10.00	-	5.00	0.72	1.93	0.53	1.25	11.88	9.08	2.63	7.56	6.61	300

OVERALL							SHAFT					KEY THK.	BEARING	
BA	C	D	L	O	P	T	U	N-W	KEYWAY				DRIVE END	OPP. DRIVE END
									R	ES	S			
4.25	24.93	6.25	11.68	12.75	12.76	2.01	1.625	4.00	1.416	2.91	0.375	0.375	6309ZC3	6309ZC3

NOTE

- 1.Dimension "D" tolerance : +0.00inch - 0.03inch
- 2.Dimension "U" tolerance : +0.000inch - 0.001inch
- 3.Dimension "R" tolerance : +0.000inch - 0.015inch

APPD BY	J. H. KIM	UNIT	INCH	SUBJECT	NEMA 256T	CAD PROJ \ FILE	XSMOUTN\A8108AA
CHKD BY	K. S. LEE	SCALE	1/8				
CHKD BY		PROJEC'N	3rd Angle	TITLE OUTLINE			
DSND BY	KIM IN KYU	DATE	2010.12.31				

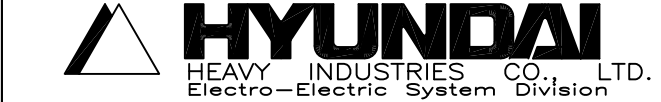

REF. NO	A1108AA	Sheet No.	of
DWG NO	350A8108AA	Revision No.	0