

본 도면은 현대중공업(주) 재산이며 복제할 수 없습니다 (취급유의)

THIS DRAWING IS PROPRIETARY TO HEECO. NO PART OF THIS DRAWING MAYBE REPRODUCED WITHOUT THE PERMISSION OF HHI.

		IEEE841 TEFC THREE PHASE INDUCTION MOTOR		TYPE	PLP Cast iron frame
FRAME SIZE	OUTPUT(HP)	POLES	Hz	TIME RATING	
365TS			60	CONT	

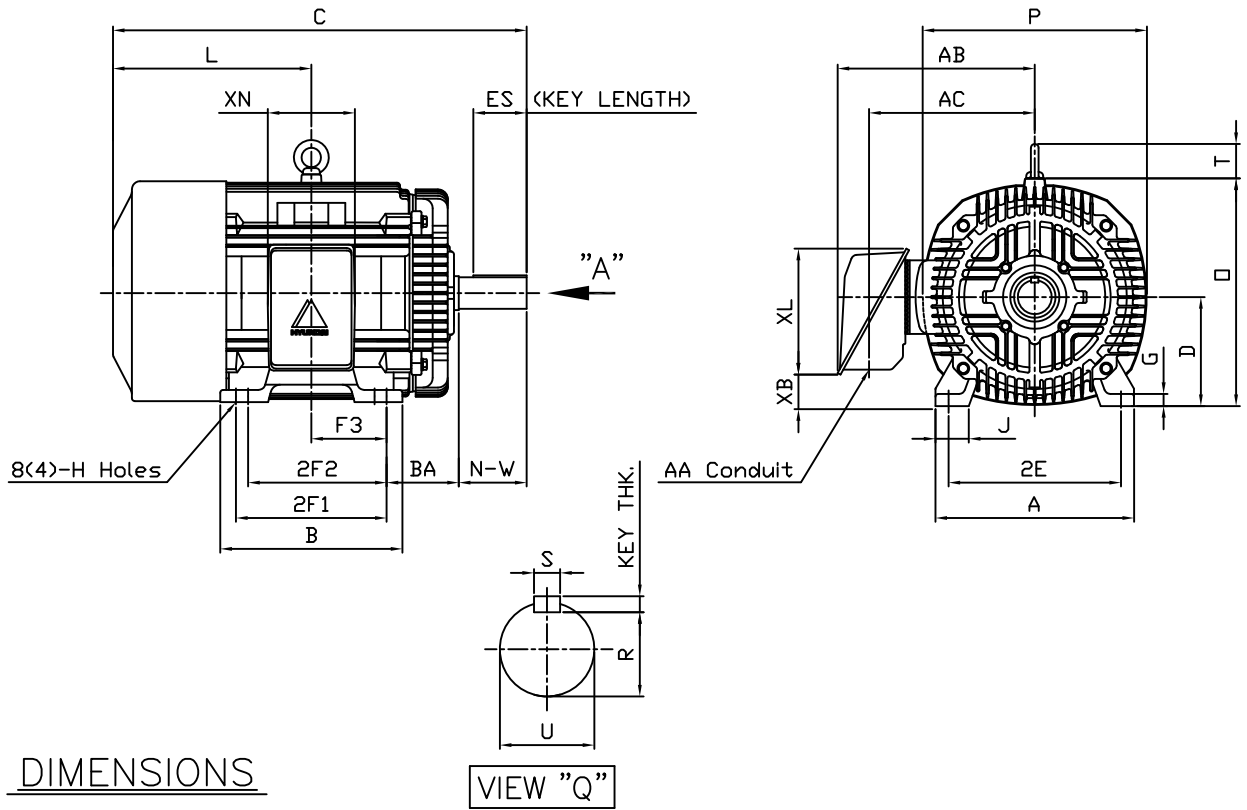

DIMENSIONS

VIEW "Q"

M O U N T I N G									C O N D U I T B O X					APPROX. WGT.(LB)	
A	B	2E	2F1	2F2	F3	G	J	H	AA	AB	AC	XB	XL	XN	
16.14	14.92	14.00	12.25	(11.25)	6.122	0.98	2.72	0.66	3.00	17.13	13.18	2.70	10.24	7.09	820

O V E R A L L							S H A F T				KEY	BEARING		
BA	C	D	L	O	P	T	U	N-W	KEYWAY			THK.	DRIVE END	OPP. DRIVE END
									R	ES	S			
5.88	33.06	9.00	17.32	18.50	18.23	2.80	1.875	3.75	1.591	2.03	0.500	0.500	6213C3	6213C3

NOTE

1. Dimension "D" tolerance : +0.00inch - 0.03inch (143T-365T) ; +0.000inch - 0.06inch (404T-449T)
2. Dimension "U" tolerance : +0.000inch - 0.005inch (143T-215T), +0.000inch - 0.001inch (254T-449T)
3. Dimension "R" tolerance : +0.000inch - 0.015inch

Q'TY	DESCRIPTION	MATERIAL	DIMENSION	WEIGHT	PART NO.	REMARK	NO.
APPD BY	K.J.KANG	UNIT	INCH	SUBJECT	365TS	CAD PROJ 명 \ FILE 명	
Q.P CHK	O.J.KIM	SCALE	N/S			MMSTDMTR\A8114BA	
CHKD BY	N.D.LEE	PROJEC'N	3 각법(3rd Angle)	TITLE			
DSND BY	A.L.SHIN	DATE	2011.03.31				
				REF. NO	A8114BA	Sheet No. of	
				DWG NO	350A8114BA	Revision No. 0	