



**IEEE 841 TEFC  
THREE PHASE INDUCTION MOTOR**

**TYPE**

PKP

CAST IRON FRAME

FRAME SIZE

OUTPUT(HP)

POLES

Hz

TIME RATING

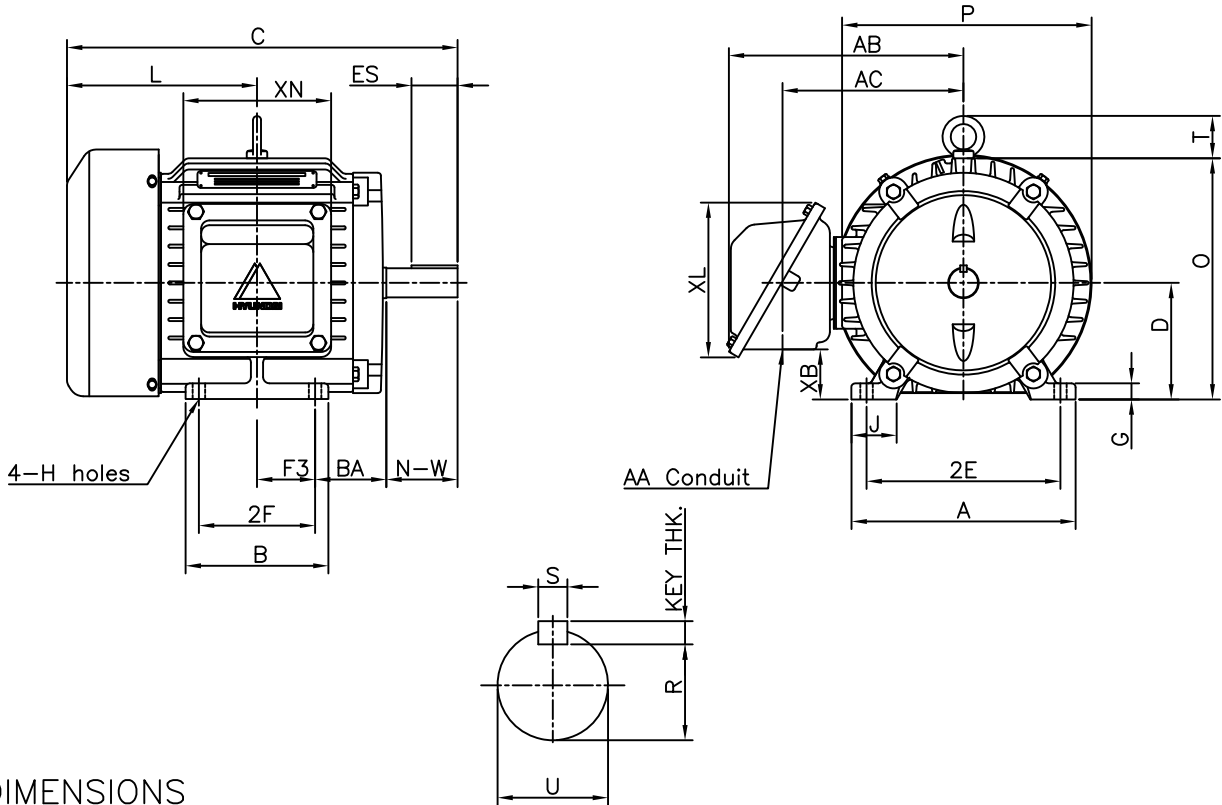

DIMENSIONS

| MOUNTING |      |      |      |   |      |      |      |      | CONDUIT BOX |      |      |      |      |      | APPROX. WGT.(LB) |
|----------|------|------|------|---|------|------|------|------|-------------|------|------|------|------|------|------------------|
| A        | B    | 2E   | 2F   | - | F3   | G    | J    | H    | AA          | AB   | AC   | XB   | XL   | XN   |                  |
| 8.66     | 5.52 | 7.50 | 4.50 | - | 2.25 | 0.62 | 1.74 | 0.41 | 0.75        | 9.06 | 7.14 | 1.93 | 5.97 | 5.71 | 90               |

| OVERALL |       |      |      |      |      |      | SHAFT |      |        |      |       | KEY THK. | BEARING   |                |
|---------|-------|------|------|------|------|------|-------|------|--------|------|-------|----------|-----------|----------------|
| BA      | C     | D    | L    | O    | P    | T    | U     | N-W  | KEYWAY |      |       |          | DRIVE END | OPP. DRIVE END |
|         |       |      |      |      |      |      |       |      | R      | ES   | S     |          |           |                |
| 2.75    | 15.09 | 4.50 | 7.34 | 9.32 | 9.64 | 1.63 | 1.125 | 2.75 | 0.986  | 1.78 | 0.250 | 0.250    | 6206ZC3   | 6206ZC3        |

**NOTE**

- 1.Dimension "D" tolerance : +0.00inch - 0.03inch
- 2.Dimension "U" tolerance : +0.000inch - 0.0005inch
- 3.Dimension "R" tolerance : +0.000inch - 0.015inch

|         |         |          |            |                         |           |                    |
|---------|---------|----------|------------|-------------------------|-----------|--------------------|
| APPD BY | J.H.KIM | UNIT     | INCH       | SUBJECT                 | NEMA 182T | CAD PROJ \ FILE    |
| CHKD BY | N.D.LEE | SCALE    | 1/8        |                         |           | SCALE-NEMA\A1103AA |
| CHKD BY | K.S.LEE | PROJEC'N | 3rd Angle  | TITLE<br><b>OUTLINE</b> |           |                    |
| DSND BY | S.W.SEO | DATE     | 2010.12.20 |                         |           |                    |

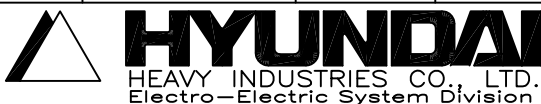

|         |            |                |
|---------|------------|----------------|
| REF. NO | 350A8103AA | Sheet No. of   |
| DWG NO  | 350A8103AA | Revision No. 0 |