

본 도면은 현대중공업(주) 재산이므로
허가없이 복사할 수 없음 (취급유의)

THIS DRAWING IS PROPRIETARY TO HEECO. NO PART OF THIS DRAWING
MAYBE REPRODUCED WITHOUT THE PERMISSION OF HHI.

		IEEE841 TEFC THREE PHASE INDUCTION MOTOR		TYPE PLP Cast iron frame
FRAME SIZE	OUTPUT(HP)	POLES	Hz	TIME RATING
444T			60	CONT

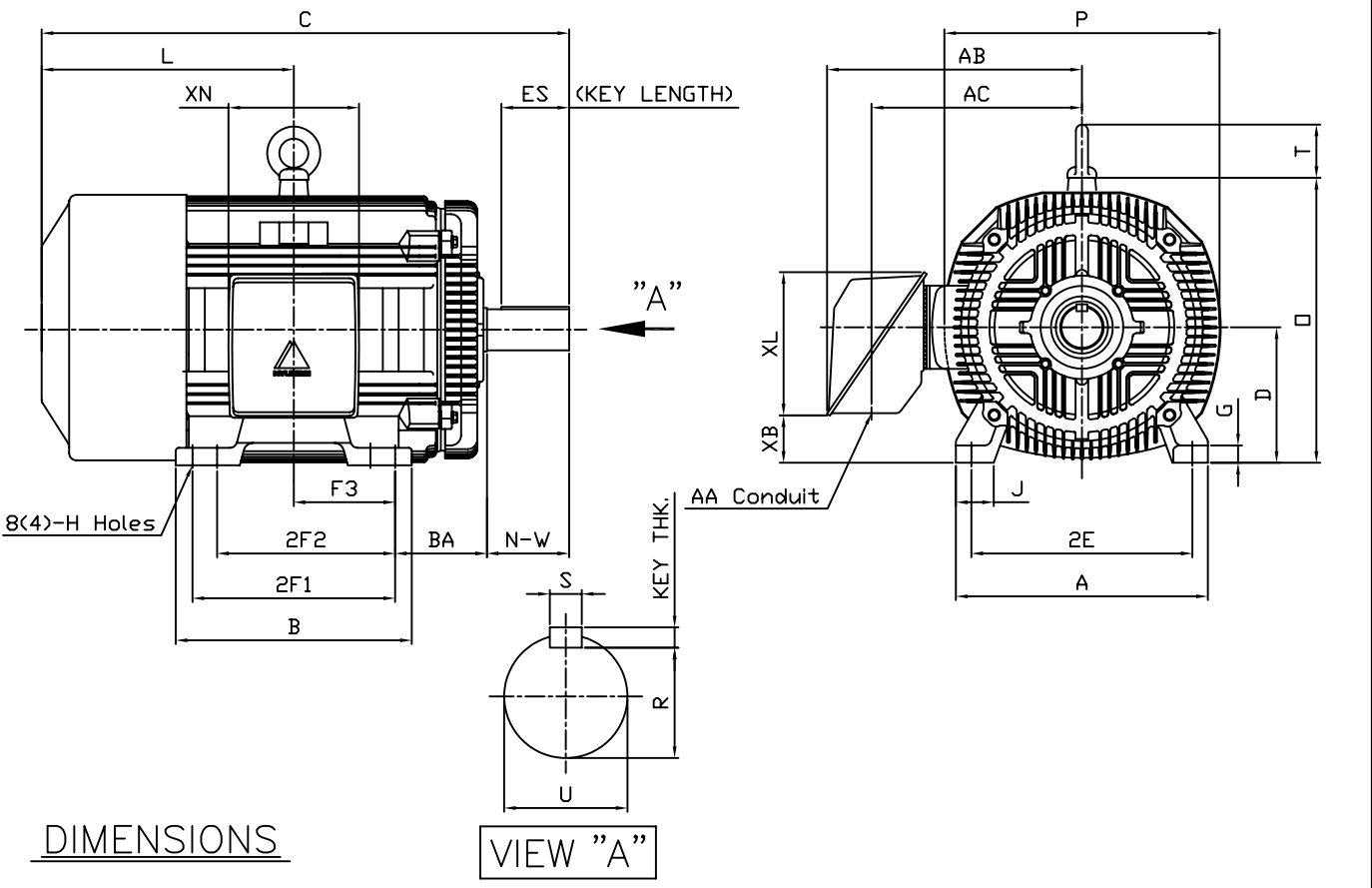

DIMENSIONS

VIEW "A"

M O U N T I N G									C O N D U I T B O X					APPROX. WGT.(LB)	
A	B	2E	2F1	2F2	F3	G	J	H	AA	AB	AC	XB	XL	XN	
20.51	19.21	18.00	(16.50)	14.50	8.248	1.42	3.07	0.81	3.00	21.26	18.03	3.83	11.65	10.63	1530

O V E R A L L							S H A F T			KEY	B E A R I N G			
BA	C	D	L	O	P	T	U	N-W	KEYWAY			THK.	DRIVE END	OPP. DRIVE END
									R	ES	S			
7.50	46.45	11.00	22.22	23.19	22.40	4.33	3.375	8.50	2.880	6.93	0.875	0.875	6318C3	6316C3

NOTE

1. Dimension "D" tolerance : +0.00inch - 0.03inch (143T-365T) ; +0.000inch - 0.06inch (404T-449T)
2. Dimension "U" tolerance : +0.000inch - 0.005inch (143T-215T), +0.000inch - 0.001inch (254T-449T)
3. Dimension "R" tolerance : +0.000inch - 0.015inch

Q'TY	DESCRIPTION	MATERIAL	DIMENSION	WEIGHT	PART NO.	REMARK	NO.
APPD BY	K.J.KANG	UNIT	INCH	SUBJECT	444T	CAD PROJ ㄹ \ FILE ㄹ	
Q.P CHK	O.J.KIM	SCALE	N/S				
CHKD BY	N.D.LEE	PROJEC'N	3 각법(3rd Angle)	TITLE OUTLINE			
DSND BY	A.L.SHIN	DATE	2011.03.31				
				REF. NO	A8117AA	Sheet No.	of
				DWG NO	350A8117AA	Revision No.	0