

본 도면은 현대중공업(주) 재산이며 복제할 수 없습니다 (취급유의)

THIS DRAWING IS PROPRIETARY TO HEECO. NO PART OF THIS DRAWING MAYBE REPRODUCED WITHOUT THE PERMISSION OF HHI.

		<b>IEEE841 TEFC</b> <b>THREE PHASE INDUCTION MOTOR</b>		<b>TYPE</b> PLP Cast iron frame
FRAME SIZE	OUTPUT(HP)	POLES	Hz	TIME RATING
444TS			60	CONT

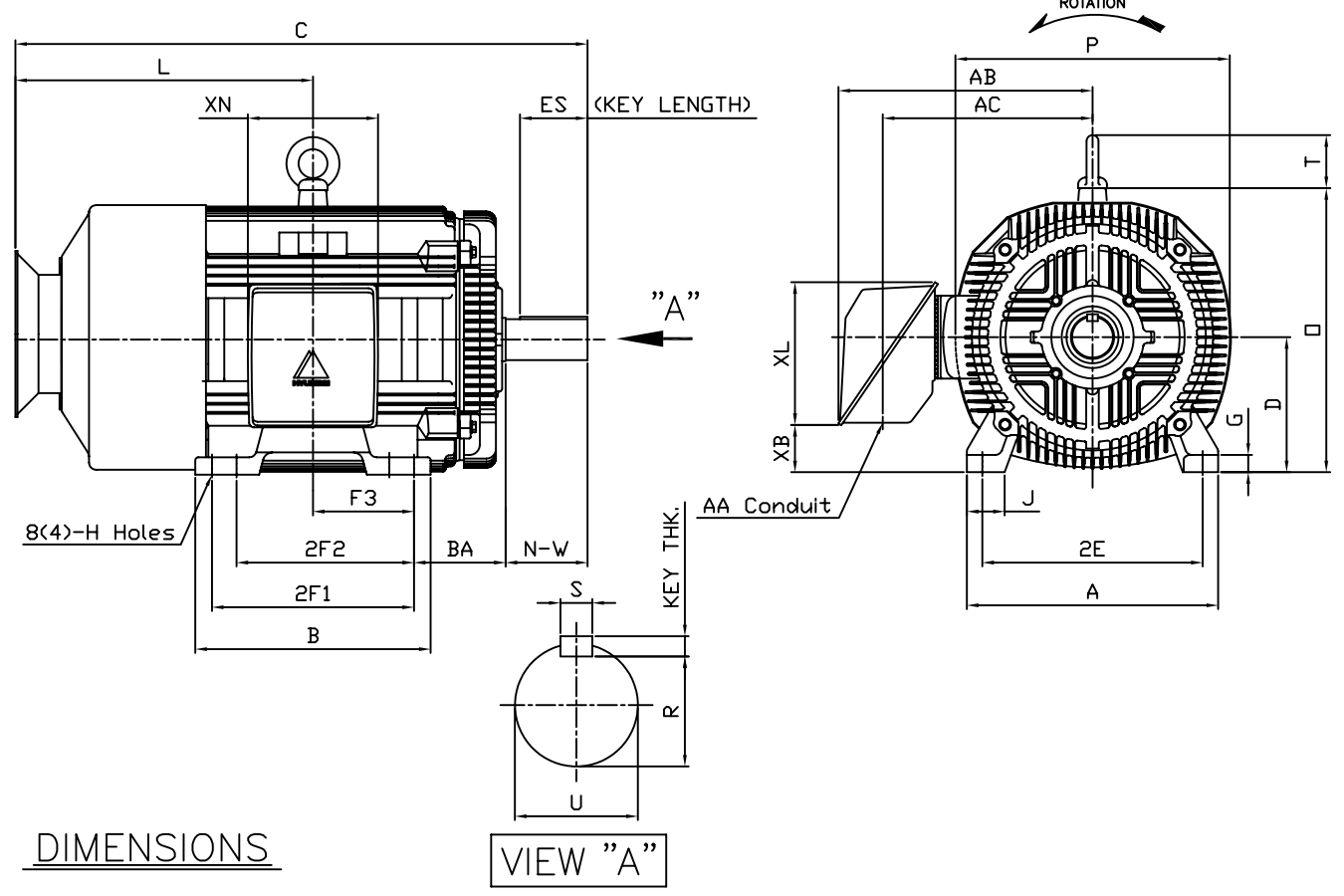

DIMENSIONS

VIEW "A"

M O U N T I N G									C O N D U I T B O X					APPROX. WGT.(LB)	
A	B	2E	2F1	2F2	F3	G	J	H	AA	AB	AC	XB	XL	XN	
20.51	19.21	18.00	(16.50)	14.50	8.248	1.42	3.07	0.81	3.00	21.26	18.03	3.83	11.65	10.63	1610

O V E R A L L							S H A F T			KEY	BEARING			
BA	C	D	L	O	P	T	U	N-W	KEYWAY			THK.	DRIVE END	OPP. DRIVE END
									R	ES	S			
7.50	47.15	11.00	26.67	23.19	22.40	4.33	2.375	4.75	2.021	3.03	0.625	0.625	6314C3	6314C3

NOTE

1. Dimension "D" tolerance : +0.00inch - 0.03inch (143T-365T) ; +0.000inch - 0.06inch (404T-449T)
2. Dimension "U" tolerance : +0.000inch - 0.005inch (143T-215T), +0.000inch - 0.001inch (254T-449T)
3. Dimension "R" tolerance : +0.000inch - 0.015inch

Q'TY	DESCRIPTION	MATERIAL	DIMENSION	WEIGHT	PART NO.	REMARK	NO.
APPD BY	K.J.KANG	UNIT	INCH	SUBJECT	444TS	CAD PROJ ㄹ \ FILE ㄹ	
Q.P CHK	O.J.KIM	SCALE	N/S				
CHKD BY	N.D.LEE	PROJEC'N	3 각법(3rd Angle)	TITLE <b>OUTLINE</b>			
DSND BY	A.L.SHIN	DATE	2011.03.31				
				REF. NO	A8117BA	Sheet No.	of
				DWG NO	350A8117BA	Revision No.	0