



TEFC

THREE PHASE INDUCTION MOTOR

TYPE

LP, JP

CAST IRON FRAME

FRAME SIZE

OUTPUT(HP)

POLES

Hz

TIME RATING

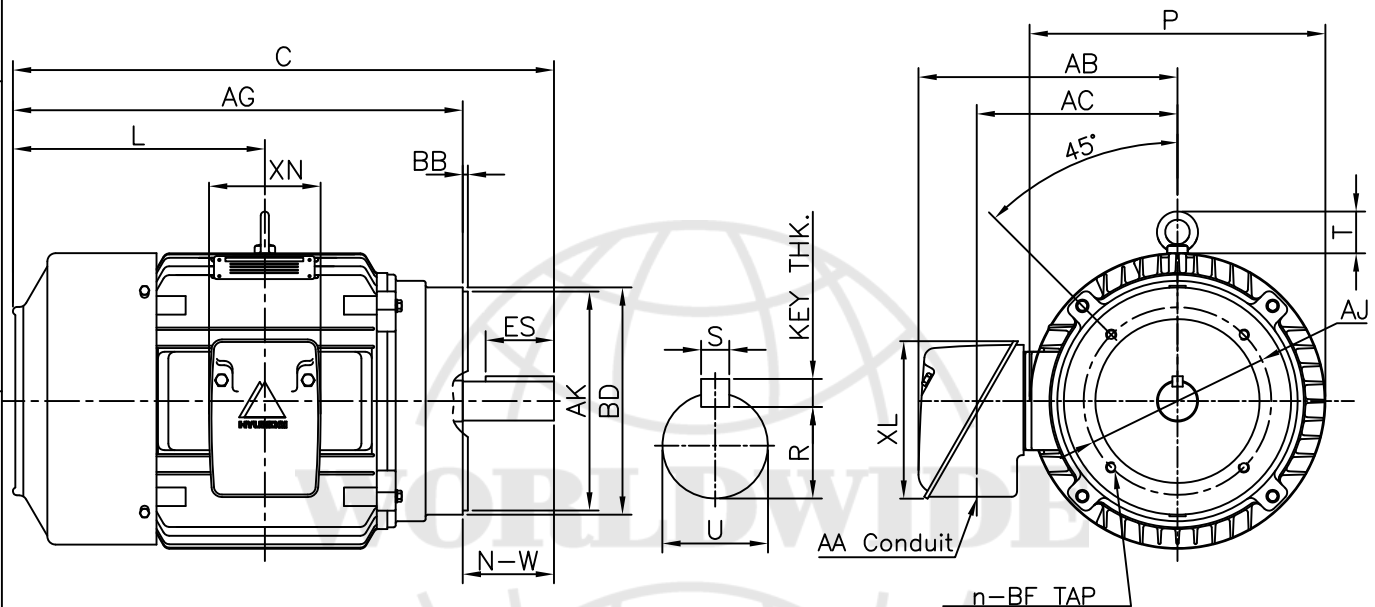

DIMENSIONS

F L A N G E						CONDUIT BOX					APPROX. WGT.(LB)
AJ	AK	BD	BB	BF	n	AA	AB	AC	XL	XN	
9.00	10.50	10.90	0.25	1/2-13	4	1.50	12.43	9.64	7.56	6.61	380

O V E R A L L							S H A F T			KEY THK.	BEARING	
AG	C	L	P	T	U	N-W	KEYWAY				DRIVE END	OPP. DRIVE END
							R	ES	S			
21.59	26.21	12.09	14.19	2.01	1.875	4.62	1.591	3.28	0.500	0.500	6310ZC3	6310ZC3

NOTE

1. Dimension "U" tolerance : +0.000inch - 0.001inch
2. Dimension "R" tolerance : +0.000inch - 0.015inch
3. Dimension "AK" tolerance : +0.000inch - 0.003inch

APPD BY	Y. S. KIM	UNIT	mm	SUBJECT	NEMA 284TC	CAD PROJ \ FILE	XSDNKS\A1509AA
CHKD BY	S. H. KO	SCALE	1/8.5				
CHKD BY		PROJEC'N	3rd Angle	TITLE OUTLINE			
DSND BY	LEE KWANG SOO	DATE	2004.04.13				
				REF. NO	A1509AA	Sheet No. of	
				DWG NO	350A1509AA	Revision No. 0	