



TEFC

THREE PHASE INDUCTION MOTOR

TYPE

LP,JP

CAST IRON FRAME

FRAME SIZE

OUTPUT(HP)

POLES

Hz

TIME RATING

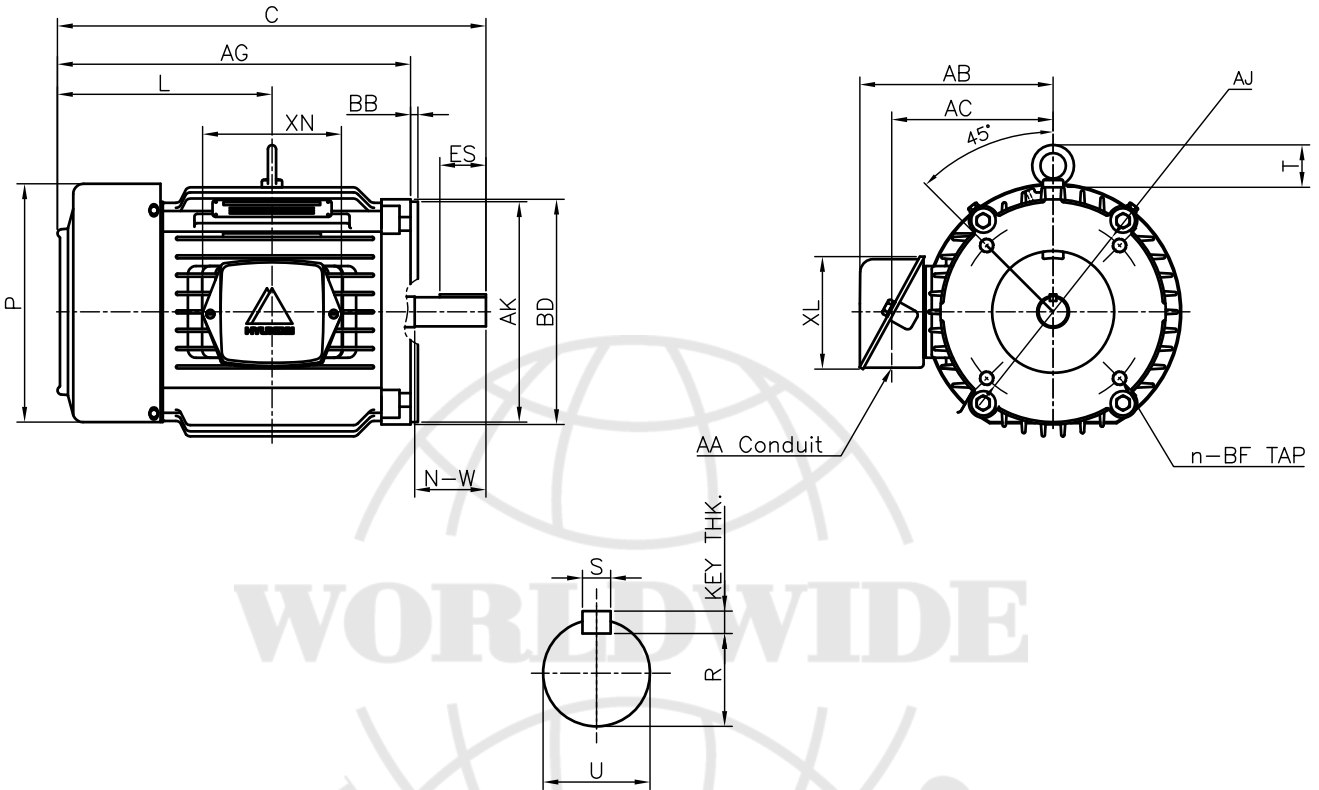

DIMENSIONS

FLANGE						CONDUIT BOX					APPROX. WGT.(LB)
AJ	AK	BD	BB	BF	n	AA	AB	AC	XL	XN	
7.250	8.50	8.70	0.25	1/2-13	4	0.75	7.47	6.23	4.35	5.35	105

O V E R A L L					S H A F T					KEY THK.	BEARING	
AG	C	L	P	T	U	N-W	KEYWAY				DRIVE END	OPP. DRIVE END
							R	ES	S			
13.64	16.55	8.29	9.21	1.63	1.125	2.75	0.986	1.78	0.250	0.250	6206ZZC3	6206ZZC3

NOTE

- 1.Dimension "D" tolerance : +0.00inch - 0.03inch
- 2.Dimension "U" tolerance : +0.000inch - 0.0005inch
- 3.Dimension "R" tolerance : +0.000inch - 0.015inch

APPD BY	J.H.KIM	UNIT	INCH	SUBJECT	NEMA 184TCH	CAD PROJ	FILE	
CHKD BY	N.D.LEE	SCALE	1/8			SCALE-NEMA\A1504AA		
CHKD BY	K.S.LEE	PROJEC'N	3rd Angle	TITLE				OUTLINE
DSND BY	S.W.SEO	DATE	2010.12.20					



REF. NO	350A1504AA	Sheet No.	of
DWG NO	350A1504AA	Revision No.	0