



TEFC

THREE PHASE INDUCTION MOTOR

TYPE

LP,JP

CAST IRON FRAME

FRAME SIZE

OUTPUT(HP)

POLES

Hz

TIME RATING

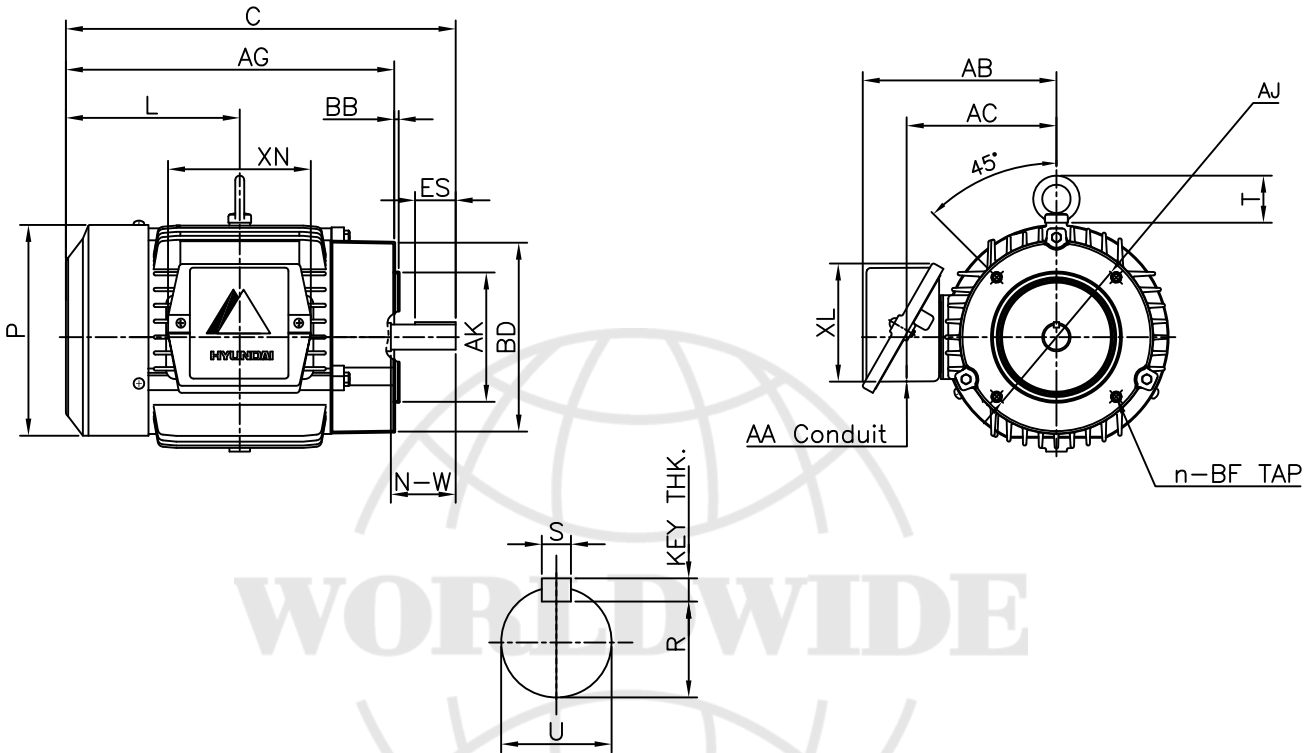

DIMENSIONS

FLANGE						CONDUIT BOX					APPROX. WGT.(LB)
AJ	AK	BD	BB	BF	n	AA	AB	AC	XL	XN	
5.875	4.50	6.57	0.16	3/8-16	4	0.75	6.73	5.21	4.10	4.96	55

O V E R A L L					S H A F T					KEY THK.	BEARING	
AG	C	L	P	T	U	N-W	KEYWAY				DRIVE END	OPP. DRIVE END
							R	ES	S			
11.42	13.05	6.05	7.33	1.63	0.875	2.25	0.771	1.41	0.188	0.188	6205ZZ	6204ZZ

NOTE

- 1.Dimension "D" tolerance : +0.00inch - 0.03inch
- 2.Dimension "U" tolerance : +0.000inch - 0.0005inch
- 3.Dimension "R" tolerance : +0.000inch - 0.015inch

APPD BY	J.H.KIM	UNIT	INCH	SUBJECT	NEMA 145TCH	CAD PROJ \ FILE
CHKD BY	N.D.LEE	SCALE	1/8			SCALE-NEMA\A1502AA
CHKD BY	K.S.LEE	PROJEC'N	3rd Angle	TITLE		
DSND BY	S.W.SEO	DATE	2010.12.20			

OUTLINE

	REF. NO	350A1502AA	Sheet No.	of
	DWG NO	350A1502AA	Revision No.	0