

<b>HYUNDAI</b> HEAVY INDUSTRIES CO., LTD.	TEFC	TYPE	LP, JP
THREE PHASE INDUCTION MOTOR			Cast iron frame

FRAME SIZE	OUTPUT(HP)	POLES	Hz	TIME RATING
364TC-F2			60	CONT

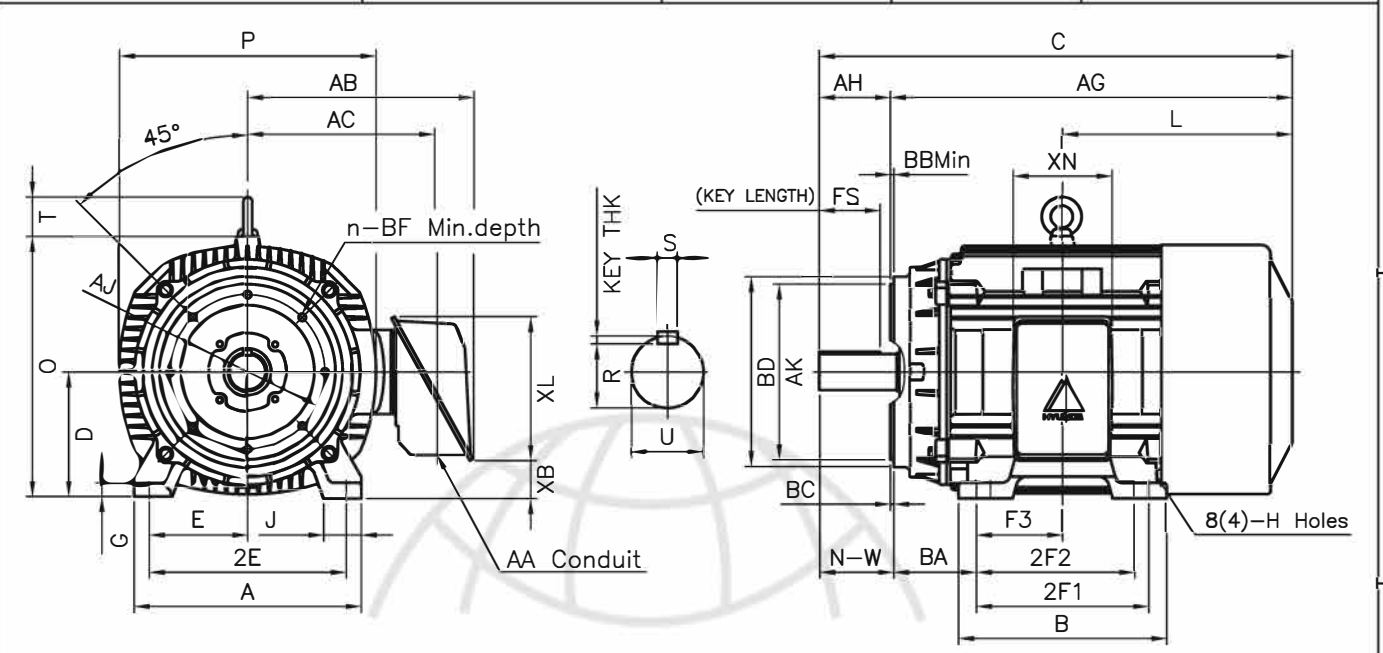

**DIMENSIONS**

M O U N T I N G									C O N D U I T B O X						APPROX. WGT.(LB)
A	B	2E	2F1	2F2	F3	G	J	H	AA	AB	AC	XB	XL	XN	
16.14	14.92	14.00	(12.25)	11.25	6.122	0.98	2.72	0.66	3.00	17.13	13.82	2.70	10.24	7.09	780

O V E R A L L									S H A F T				KEY	B E A R I N G	
BA	C	D	L	O	P	T	AG	U	N-W	KEYWAY			THK.	DRIVE END	OPP. DRIVE END
										R	ES	S			
5.88	34.01	9.00	16.13	18.50	17.75	2.80	28.13	2.375	5.88	2.021	4.28	0.625	0.625	6314C3	6213C3

C - F A C E								
AJ	AK	BB Min	BC	BD	BF	BF depth	n	AH
11.00	12.50	0.25	0.25	13.38	5/8-11	0.94	8	5.62

**NOTE**

- 1.Dimension "D" tolerance : +0.00inch ~ -0.03inch (143TC-365TC) : +0.000inch ~ -0.06inch (404TC-449TC)
- 2.Dimension "U" tolerance : +0.000inch ~ -0.0005inch (143TC-215TC): +0.000inch ~ -0.001inch (254TC-449TC)
- 3.Dimension "R" tolerance : +0.000inch ~ - 0.015inch
- 4.Dimension "AK" tolerance : +0.000inch ~ -0.003inch (143TC-286TC): +0.000inch ~ -0.005inch (324TC-449TC)

APPD BY	K.J. KANG	UNIT	INCH	SUBJECT	364TC	CAD PROJ \ FILE	
CHKD BY		SCALE	N/S	TITLE	OUTLINE	MMSTDMTR\A1313AA	
CHKD BY		PROJEC'N	3rd Angle				
DSND BY	N.D.LEE	DATE	2011.02.09				

<b>HYUNDAI</b> HEAVY INDUSTRIES CO., LTD. Electro-Electric System Division	REF. NO	A1313AA	Sheet No. of
	DWG NO	350A1313AA	Revision No. 0