

| | | | |
|---|------|------|-----------------|
|  | TEFC | TYPE | LP, JP |
| THREE PHASE INDUCTION MOTOR | | | Cast iron frame |

| | | | | |
|-----------|------------|-------|----|-------------|
| FRAME | OUTPUT(HP) | POLES | Hz | TIME RATING |
| 445TSC-F2 | | | 60 | CONT |

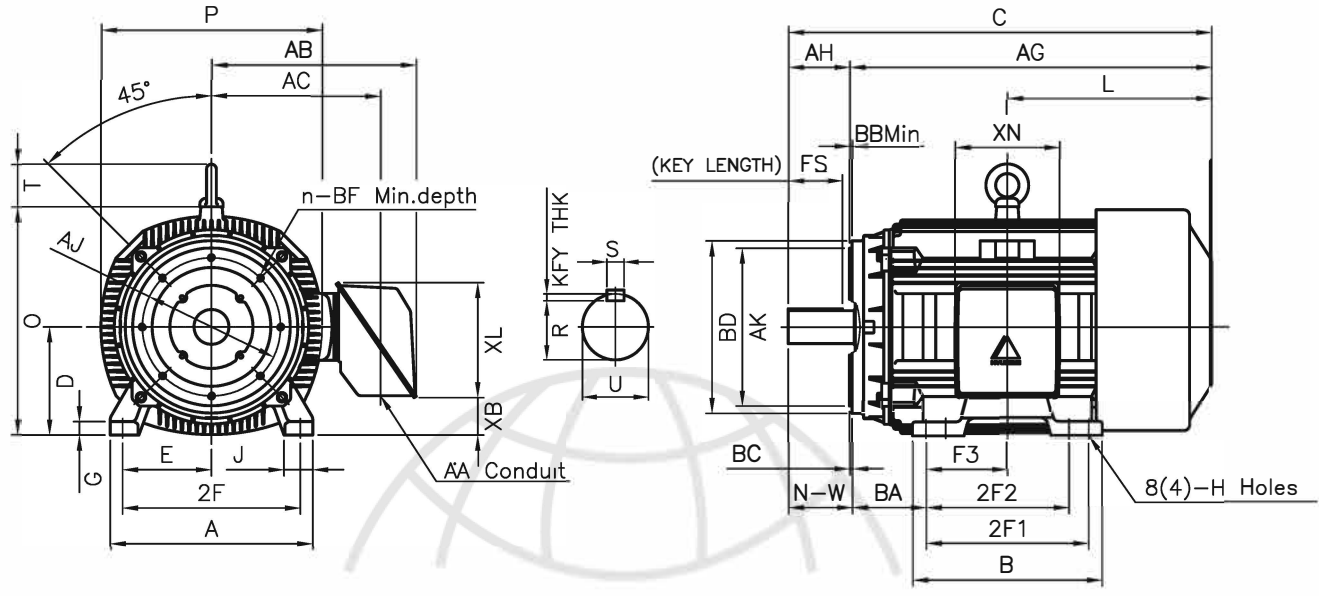

DIMENSIONS

| M O U N T I N G | | | | | | | | | C O N D U I T B O X | | | | | | APPROX. WGT.(LB) |
|-----------------|-------|-------|-------|---------|-------|------|------|------|---------------------|-------|-------|------|-------|-------|------------------|
| A | B | 2E | 2F1 | 2F2 | F3 | G | J | H | AA | AB | AC | XB | XL | XN | |
| 20.51 | 19.21 | 18.00 | 16.50 | (14.50) | 8.248 | 1.42 | 3.07 | 0.81 | 3.00 | 21.26 | 18.03 | 3.83 | 11.65 | 10.63 | 1770 |

| O V E R A L L | | | | | | | | S H A F T | | | | KEY | BEARING | | |
|---------------|-------|-------|-------|-------|-------|------|-------|-----------|------|--------|------|-------|---------|-----------|----------------|
| BA | C | D | L | O | P | T | AG | U | N-W | KEYWAY | | | THK. | DRIVE END | OPP. DRIVE END |
| | | | | | | | | | | R | ES | S | | | |
| 7.50 | 41.46 | 11.00 | 20.96 | 23.19 | 22.44 | 4.33 | 36.71 | 2.375 | 4.75 | 2.021 | 3.03 | 0.625 | 0.625 | 6314C3 | 6314C3 |

| C - F A C E | | | | | | | | |
|-------------|-------|--------|------|-------|--------|----------|---|------|
| AJ | AK | BB Min | BC | BD | BF | BF depth | n | AH |
| 14.00 | 16.00 | 0.25 | 0.25 | 16.93 | 5/8-11 | 0.94 | 8 | 4.50 |

NOTE

- 1.Dimension "D" tolerance : +0.00inch ~ -0.03inch (143TC-365TC) : +0.000inch ~ -0.06inch (404TC-449TC)
- 2.Dimension "U" tolerance : +0.000inch ~ -0.0005inch (143TC-215TC): +0.000inch ~ -0.001inch (254TC-449TC)
- 3.Dimension "R" tolerance : +0.000inch ~ - 0.015inch
- 4.Dimension "AK" tolerance : +0.000inch ~ -0.003inch (143TC-286TC): +0.000inch ~ -0.005inch (324TC-449TC)

| | | | | | | | | |
|---------|-----------|----------|------------|---------|---------|------------------|--|--|
| APPD BY | K.J. KANG | UNIT | INCH | SUBJECT | 445TSC | CAD PROJ \ FILE | | |
| CHKD BY | | SCALE | N/S | TITLE | OUTLINE | MMSTDMTR\A1318BA | | |
| CHKD BY | | PROJEC'N | 3rd Angle | | | | | |
| DSND BY | N.D.LEE | DATE | 2011.02.09 | | | | | |

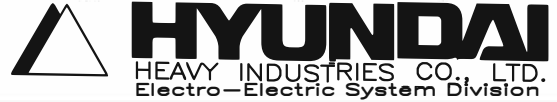

| | | | |
|---------|------------|--------------|---|
| REF. NO | A1318BA | Sheet No. of | |
| DWG NO | 350A1318BA | Revision No. | 0 |