



TEFC

THREE PHASE INDUCTION MOTOR

TYPE

LP, JP

CAST IRON FRAME

FRAME SIZE

OUTPUT(HP)

POLES

Hz

TIME RATING

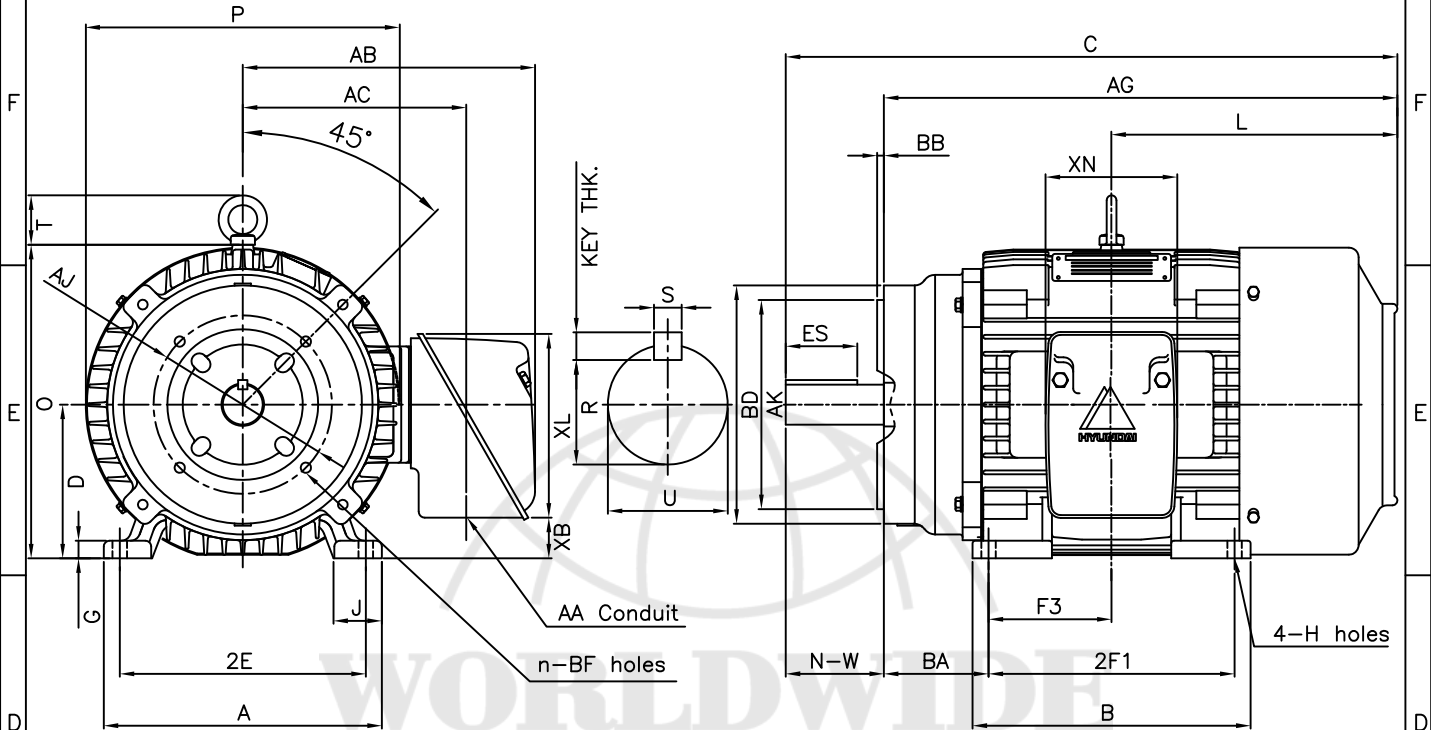

DIMENSIONS

F L A N G E						M O U N T I N G								
AJ	AK	BD	BB	BF	n	A	B	2E	2F1	2F2	F3	G	J	H
7.25	8.50	9.68	0.25	1/2-13	4	11.30	11.30	10.00	10.00	-	5.00	0.72	1.93	0.53

C O N D U I T B O X						O V E R A L L								APPROX. WGT.(LB)
AA	AB	AC	XB	XL	XN	AG	BA	C	D	L	O	P	T	
1.25	11.88	9.08	2.63	7.56	6.61	20.86	4.25	24.86	6.25	11.61	12.75	12.76	2.01	300

S H A F T					KEY THK.	B E A R I N G	
U	N-W	KEYWAY				DRIVE END	OPP. DRIVE END
		R	ES	S			
1.625	4.00	1.416	2.91	0.375	0.375	6309ZC3	6309ZC3

NOTE

- 1.Dimension "D" tolerance : +0.00inch - 0.03inch
- 2.Dimension "U" tolerance : +0.000inch - 0.0005inch
- 3.Dimension "R" tolerance : +0.000inch - 0.015inch

APPD BY	KIM.Y.S	UNIT	INCH	SUBJECT	NEMA 256TC(KIT)	CAD PROJ \ FILE
CHKD BY	KO.S.H	SCALE	N/S			XSMOUTN\A1308AA
CHKD BY		PROJEC'N	3rd Angle	TITLE OUTLINE		
DSND BY	Y.J.HWANG	DATE	2004.11.19			
				REF. NO	A1308AA	Sheet No. of
				DWG NO	350A1308AA	Revision No. 0