

본 도면은 현대중공업(주) 재산이므로  
허가없이 복사할 수 없음 (취급유의)

THIS DRAWING IS PROPRIETARY TO HHI. NO PART OF THIS DRAWING  
MAYBE REPRODUCED WITHOUT THE PERMISSION OF HHI.

	<h1 style="margin:0;">TEFC</h1> <h2 style="margin:0;">THREE PHASE INDUCTION MOTOR</h2>	<h3 style="margin:0;">TYPE</h3>	LP, JP <hr/> Cast iron frame
--	--	---------------------------------	---------------------------------

FRAME SIZE	OUTPUT(HP)	POLES	Hz	TIME RATING
447TC			60	CONT

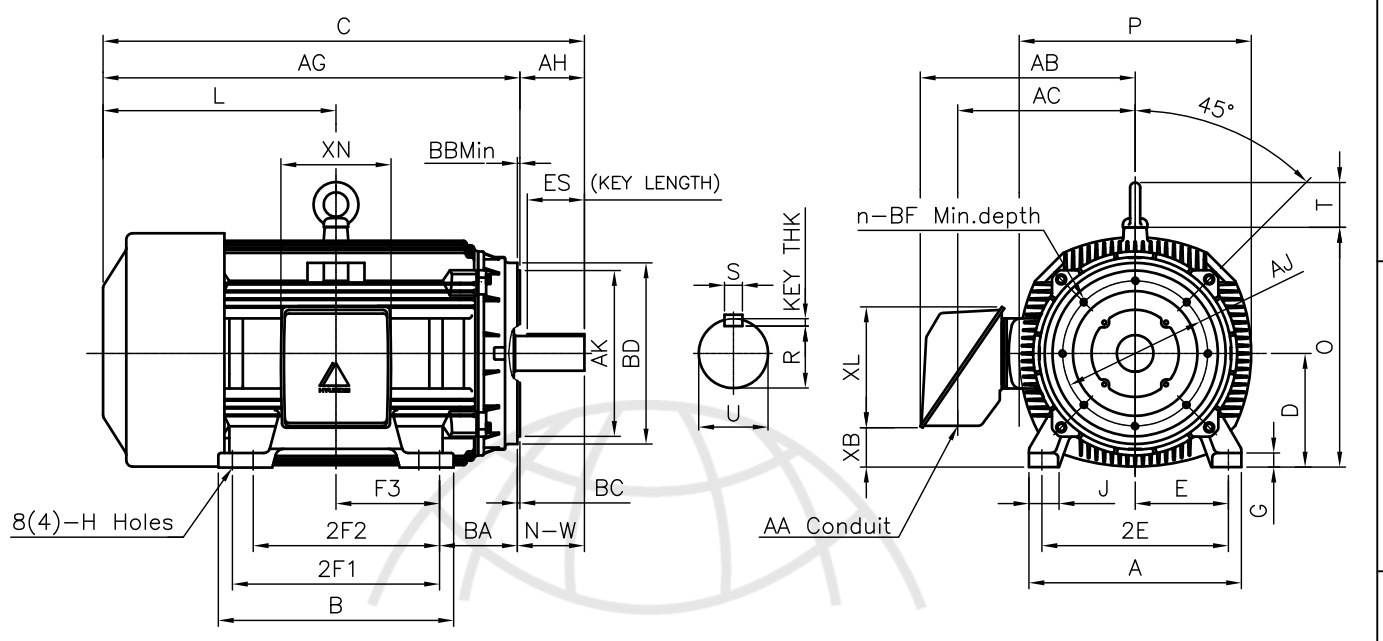

### DIMENSIONS

M O U N T I N G									C O N D U I T B O X					APPROX. WGT.(LB)	
A	B	2E	2F1	2F2	F3	G	J	H	AA	AB	AC	XB	XL		XN
20.51	22.72	18.00	20.00	(17.99)	10.000	1.42	3.07	0.81	3.00	21.26	18.03	3.83	11.65	10.63	1970

O V E R A L L								S H A F T					KEY	BEARING	
BA	C	D	L	O	P	T	AG	U	N-W	KEYWAY			THK.	DRIVE END	OPP. DRIVE END
										R	ES	S			
7.50	48.71	11.00	22.71	23.19	22.44	4.33	40.21	3.375	8.50	2.880	6.93	0.875	0.875	6318C3	6316C3

D - F L A N G E								
AJ	AK	BB Min	BC	BD	BF	BF depth	n	AH
14.00	16.00	0.25	0.25	16.93	5/8-11	0.94	8	8.25

#### NOTE

- 1.Dimension "D" tolerance : +0.00inch ~ -0.03inch (143TC-365TC) : +0.000inch ~ -0.06inch (404TC-449TC)
- 2.Dimension "U" tolerance : +0.000inch ~ -0.0005inch (143TC-215TC): +0.000inch ~ -0.001inch (254TC-449TC)
- 3.Dimension "R" tolerance : +0.000inch ~ - 0.015inch
- 4.Dimension "AK" tolerance : +0.000inch ~ -0.003inch (143TC-286TC): +0.000inch ~ -0.005inch (324TC-449TC)

APPD BY	K.J. KANG	UNIT	INCH	SUBJECT	447TC	CAD PROJ \ FILE
CHKD BY		SCALE	N/S	TITLE	<h2 style="margin:0;">OUTLINE</h2>	MMSTDMTR\A1319AA
CHKD BY		PROJEC'N	3rd Angle			
DSND BY	N.D.LEE	DATE	2011.02.09			

	REF. NO	A1319AA	Sheet No. of
	DWG NO	350A1319AA	Revision No. 0