	<h1 style="margin:0;">TEFC</h1> <h2 style="margin:0;">THREE PHASE INDUCTION MOTOR</h2>	<h3 style="margin:0;">TYPE</h3>	LP, JP <hr/> Cast iron frame
---	--	---------------------------------	---------------------------------

FRAME SIZE	OUTPUT(HP)	POLES	Hz	TIME RATING
405TC			60	CONT

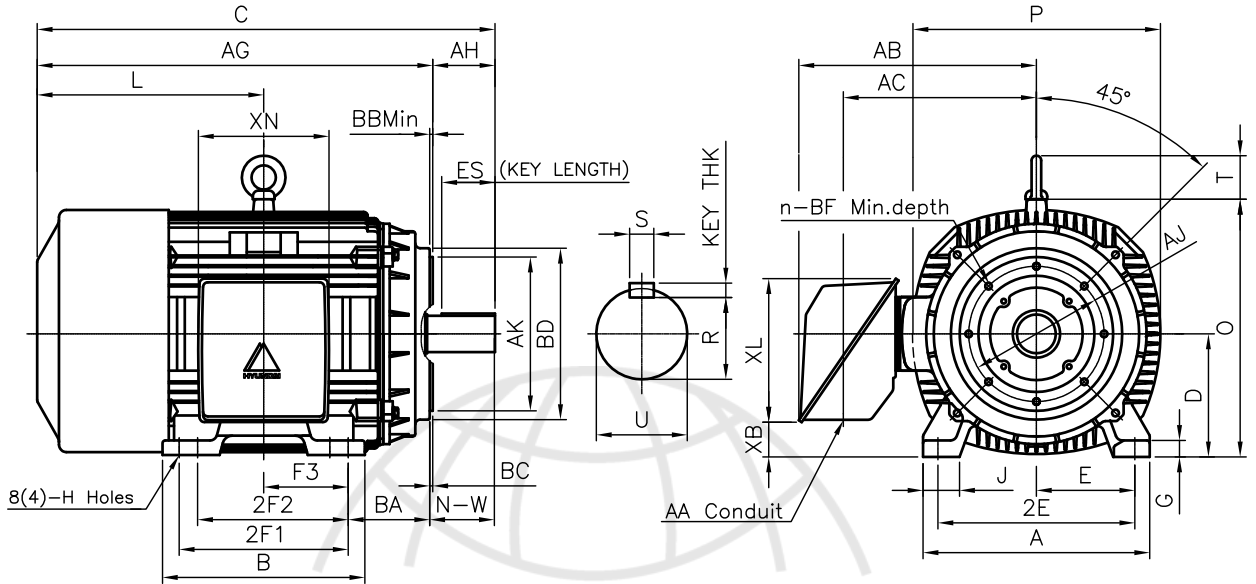

DIMENSIONS



M O U N T I N G									C O N D U I T B O X					APPROX. WGT.(LB)	
A	B	2E	2F1	2F2	F3	G	J	H	AA	AB	AC	XB	XL		XN
18.43	16.46	16.00	13.75	(12.25)	6.870	1.18	3.03	0.81	3.00	20.28	14.85	2.83	11.65	10.63	1110

O V E R A L L								S H A F T					KEY	BEARING	
BA	C	D	L	O	P	T	AG	U	N-W	KEYWAY			THK.	DRIVE END	OPP. DRIVE END
										R	ES	S			
6.62	39.42	10.00	18.68	20.79	19.69	3.55	32.17	2.875	7.25	2.450	5.65	0.750	0.750	6316C3	6313C3

C - F A C E								
AJ	AK	BB Min	BC	BD	BF	BF depth	n	AH
11.00	12.50	0.25	0.25	13.78	5/8-11	0.94	8	7.00

NOTE

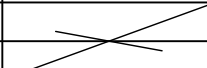
- 1.Dimension "D" tolerance : +0.00inch ~ -0.03inch (143TC-365TC) : +0.000inch ~ -0.06inch (404TC-449TC)
- 2.Dimension "U" tolerance : +0.000inch ~ -0.0005inch (143TC-215TC): +0.000inch ~ -0.001inch (254TC-449TC)
- 3.Dimension "R" tolerance : +0.000inch ~ - 0.015inch
- 4.Dimension "AK" tolerance : +0.000inch ~ -0.003inch (143TC-286TC): +0.000inch ~ -0.005inch (324TC-449TC)

APPD BY	K.J. KANG	UNIT	INCH	SUBJECT	405TC	CAD PROJ \ FILE	
CHKD BY		SCALE	N/S	TITLE	<h2 style="margin:0;">OUTLINE</h2>	MMSTDMTR\A1316AA	
CHKD BY		PROJEC'N	3rd Angle				
DSND BY	N.D.LEE	DATE	2011.02.09				