



# TEFC

**THREE PHASE INDUCTION MOTOR**

**TYPE**

LP, JP

CAST IRON FRAME

FRAME SIZE

OUTPUT(HP)

POLES

Hz

TIME RATING

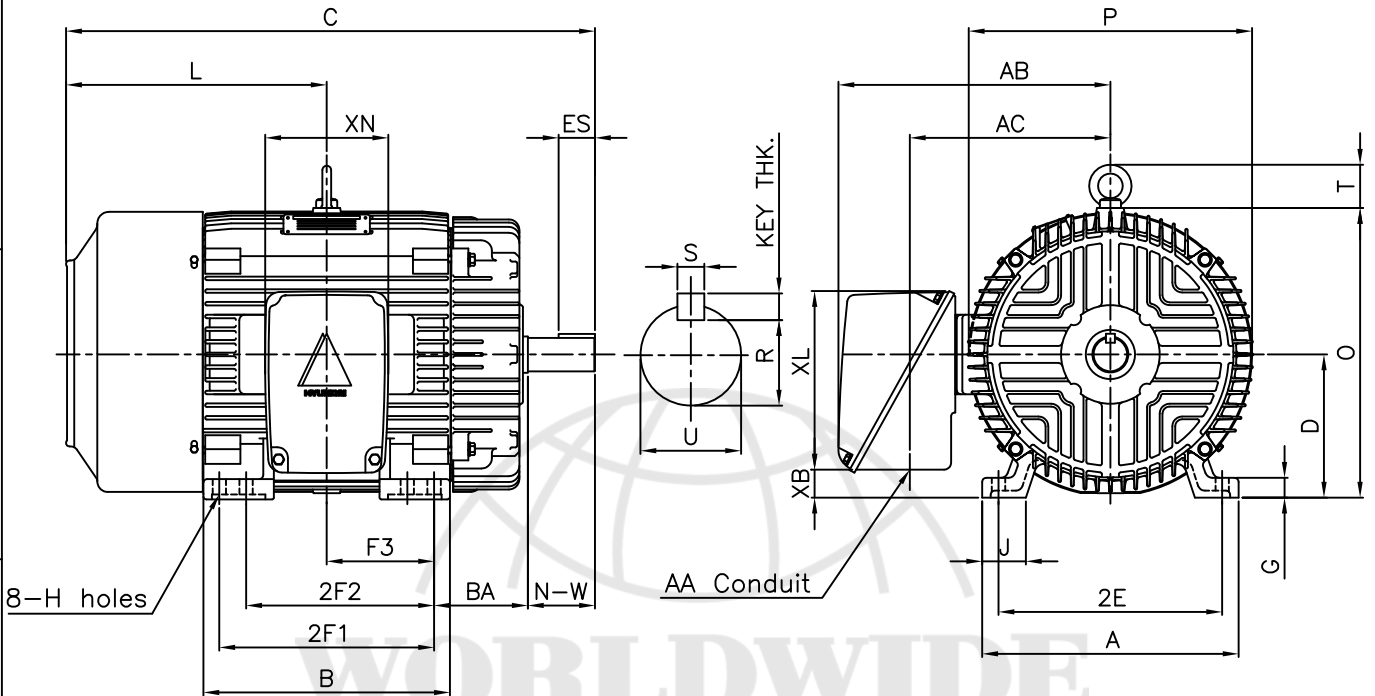

## DIMENSIONS

M O U N T I N G									C O N D U I T B O X						APPROX. WGT.(LB)	
A	B	2E	2F1 <sup>5)</sup>	2F2 <sup>4)</sup>	F3	G	J	H	AA	AB	AC	XB	XL	XN	324TS	326TS
14.33	13.78	12.50	12.00	10.50	6.00	1.11	2.36	0.66	2.00	15.20	11.21	1.57	10.16	7.01	530	540

O V E R A L L							S H A F T					KEY THK.	B E A R I N G	
BA	C	D	L	O	P	T	U	N-W	KEYWAY				DRIVE END	OPP. DRIVE END
									R	ES	S			
5.25	29.57	8.00	14.57	16.19	15.84	2.41	1.875	3.75	1.591	2.03	0.500	0.500	6313ZC3	6211ZC3

### NOTE

- 1.Dimension "D" tolerance : +0.00inch - 0.03inch
- 2.Dimension "U" tolerance : +0.000inch - 0.001inch
- 3.Dimension "R" tolerance : +0.000inch - 0.015inch
- 4.Location of holes for 324TS frame
- 5.Location of holes for 326TS frame

APPD BY	KIM.Y.S	UNIT	INCH	SUBJECT	NEMA 324TS/326TS	CAD PROJ \ FILE	
CHKD BY	KO.S.H	SCALE	1/12			XSMOUTN\A1112BA	
CHKD BY		PROJEC'N	3rd Angle	TITLE <b>OUTLINE</b>			
DSND BY	LEE KWANG SOO	DATE	2004.04.02				
				REF. NO	A1112BA	Sheet No. of	
				DWG NO	350A1112BA	Revision No. 0	