

본 도면은 현대중공업(주) 재산이므로  
허가없이 복사할 수 없음 (취급유의)

THIS DRAWING IS PROPRIETARY TO HEECO. NO PART OF THIS DRAWING  
MAYBE REPRODUCED WITHOUT THE PERMISSION OF HHI.

		<h1>T E F C</h1> <h2>THREE PHASE INDUCTION MOTOR</h2>		<b>TYPE</b> LP, JP Cast iron frame
FRAME SIZE	OUTPUT(HP)	POLES	Hz	TIME RATING
364T-4P			60	CONT

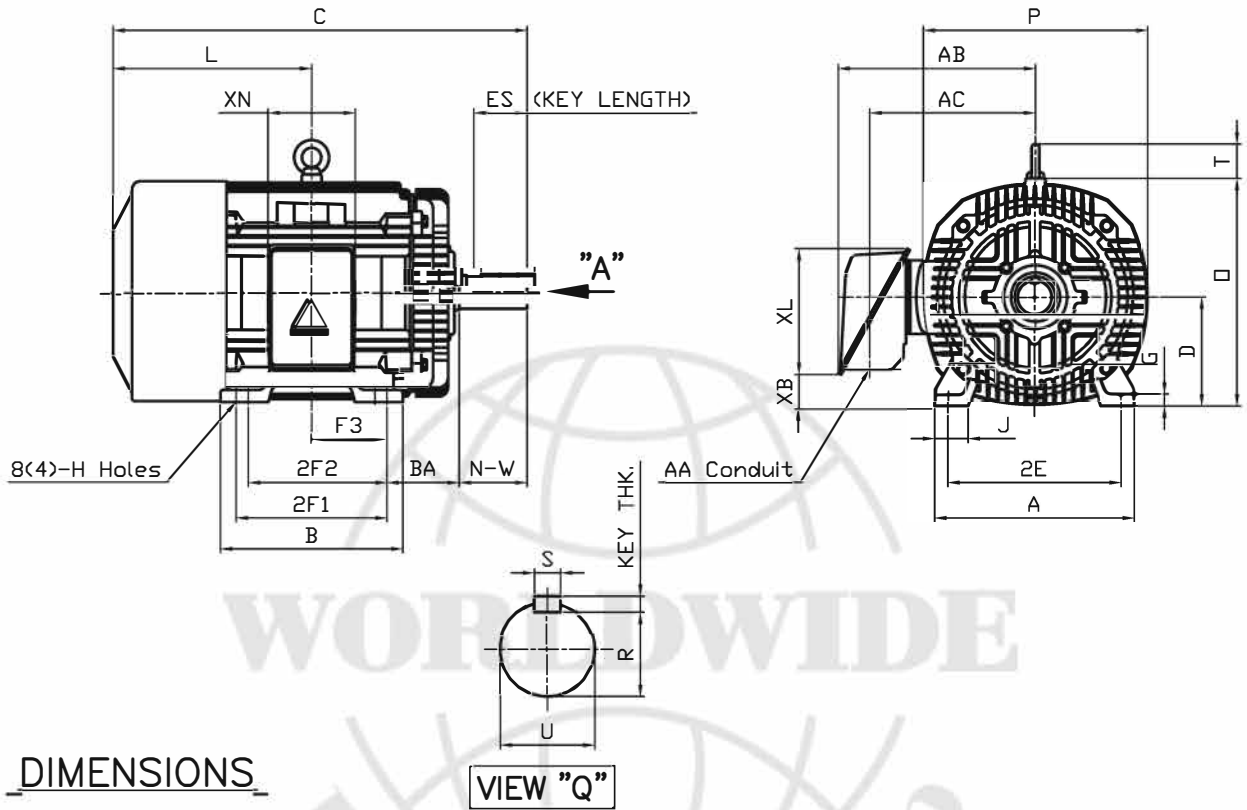

**DIMENSIONS**

VIEW "Q"

M O U N T I N G									C O N D U I T B O X					APPROX. WGT.(LB)	
A	B	2E	2F1	2F2	F3	G	J	H	AA	AB	AC	XB	XL	XN	
16.14	14.92	14.00	(12.25)	11.25	6.122	0.98	2.72	0.66	3.00	17.13	13.82	2.70	10.24	7.09	780

O V E R A L L								S H A F T			KEY	B E A R I N G		
BA	C	D	L	O	P	T	U	N-W	KEYWAY			THK.	DRIVE END	OPP. DRIVE END
									R	ES	S			
5.88	34.01	9.00	16.13	18.50	18.23	2.80	2.375	5.88	2.021	4.28	0.625	0.625	6314C3	6213C3

**NOTE**

- Dimension "D" tolerance : +0.00inch - 0.03inch (143T-365T) ; +0.000inch - 0.06inch (404T-449T)
- Dimension "U" tolerance : +0.000inch - 0.005inch (143T-215T), +0.000inch - 0.001inch (254T-449T)
- Dimension "R" tolerance : +0.000inch - 0.015inch

Q'TY	DESCRIPTION	MATERIAL	DIMENSION	WEIGHT	PART NO.	REMARK	NO.
APPD BY	K.J. KANG	UNIT	INCH	SUBJECT	364T	CAD PROJ	FILE
Q.P CHK		SCALE	N/S	TITLE	OUTLINE		
CHKD BY		PROJEC'N	3 각법(3rd Angle)	REF. NO	A1113AA	Sheet No.	of
DSND BY	N.D.Lee	DATE	2011.01.12	DWG NO	350A1113AA	Revision No.	0