



TEFC

THREE PHASE INDUCTION MOTOR

TYPE

LP, JP

CAST IRON FRAME

FRAME SIZE

OUTPUT(HP)

POLES

Hz

TIME RATING

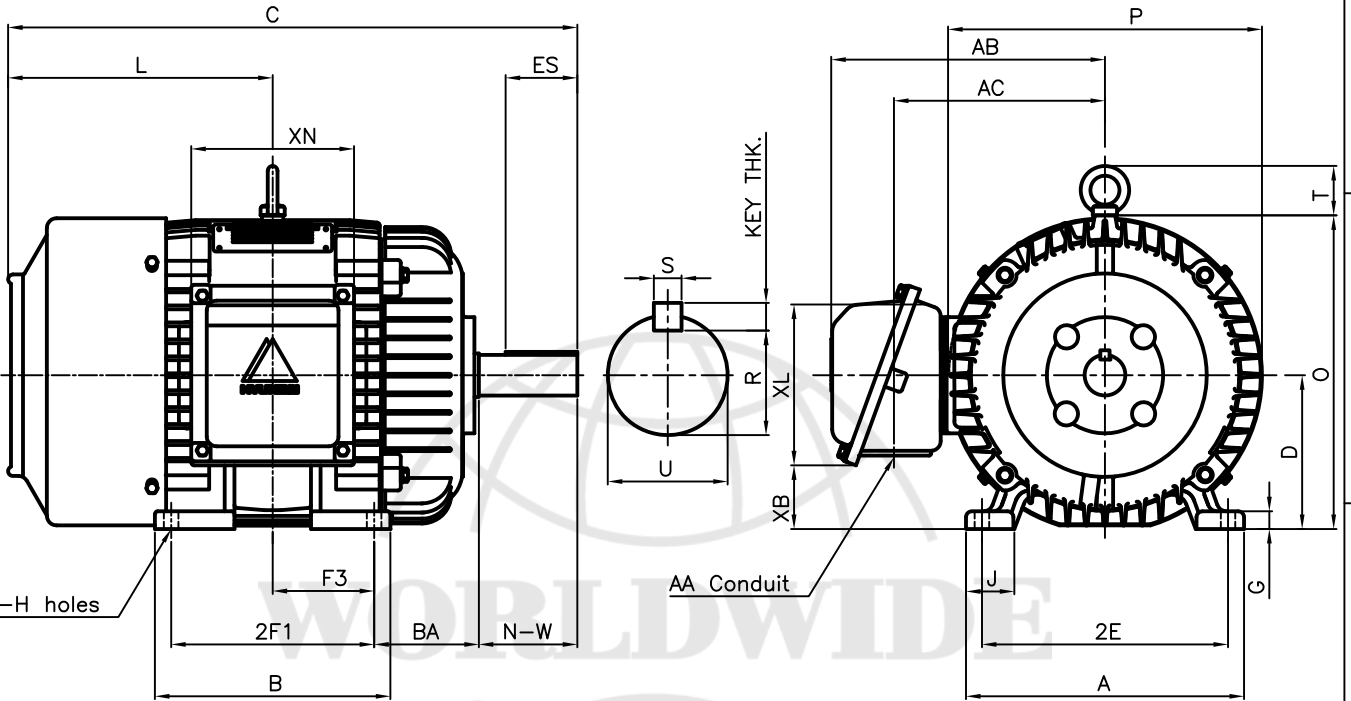

DIMENSIONS

MOUNTING									CONDUIT BOX						APPROX. WGT.(LB)
A	B	2E	2F1	2F2	F3	G	J	H	AA	AB	AC	XB	XL	XN	
11.30	9.56	10.00	8.25	-	4.13	0.72	1.93	0.53	1.25	11.88	9.08	2.63	7.56	6.61	260

OVERALL							SHAFT			KEY THK.	BEARING			
BA	C	D	L	O	P	T	U	N-W	KEYWAY		DRIVE END	OPP. DRIVE END		
									R	ES	S			
4.25	23.13	6.25	10.75	12.75	12.76	2.01	1.625	4.00	1.416	2.91	0.375	0.375	6309ZC3	6309ZC3

NOTE

- 1.Dimension "D" tolerance : +0.00inch - 0.03inch
- 2.Dimension "U" tolerance : +0.000inch - 0.001inch
- 3.Dimension "R" tolerance : +0.000inch - 0.015inch

APPD BY	J. H. KIM	UNIT	INCH	SUBJECT	NEMA 254T	CAD PROJ \ FILE	XSMOUTN\A1107AA	
CHKD BY	K. S. LEE	SCALE	N/S					
CHKD BY		PROJEC'N	3rd Angle	TITLE				OUTLINE
DSND BY	KIM IN KYU	DATE	2010.12.31					
				REF. NO	A1107AA	Sheet No. of		
				DWG NO	350A1107AA	Revision No. 0		