

본 도면은 현대중공업(주) 재산이므로
허가없이 복사할 수 없음 (취급주의)

THIS DRAWING IS PROPRIETARY TO HEECO. NO PART OF THIS DRAWING
MAYBE REPRODUCED WITHOUT THE PERMISSION OF HHI.

		<h1>TEFC</h1> <h2>THREE PHASE INDUCTION MOTOR</h2>		TYPE LP, JP Cast iron frame
FRAME SIZE	OUTPUT(HP)	POLES	Hz	TIME RATING
445T-F2			60	CONT

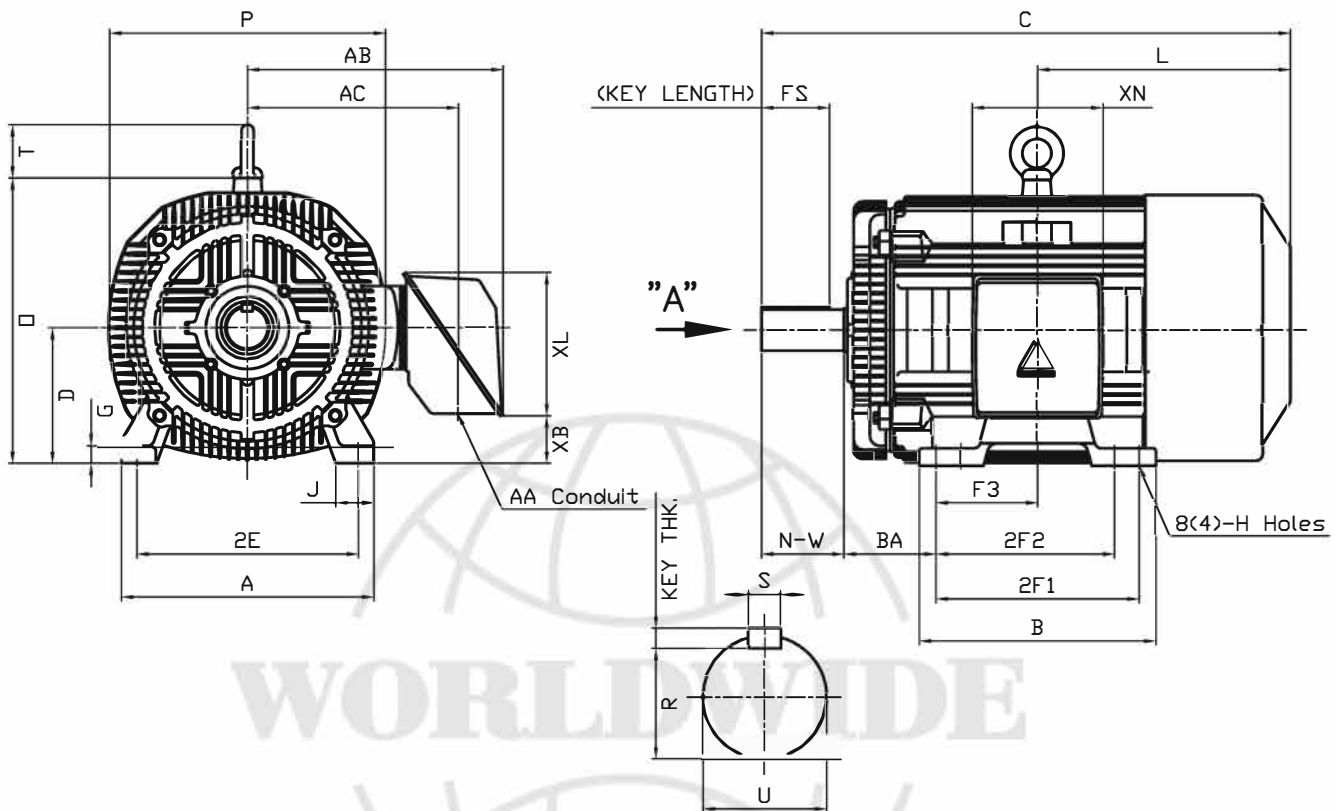

DIMENSIONS

VIEW "A"

M O U N T I N G									C O N D U I T B O X					APPROX. WGT.(LB)	
A	B	2E	2F1	2F2	F3	G	J	H	AA	AB	AC	XB	XL		XN
20.51	19.21	18.00	16.50	(14.50)	8.248	1.42	3.07	0.81	3.00	21.26	18.03	3.83	11.65	10.63	1640

O V E R A L L								S H A F T			KEY	BEARING		
BA	C	D	L	O	P	T	U	N-W	KEYWAY			THK.	DRIVE END	OPP. DRIVE END
									R	ES	S			
7.50	45.21	11.00	20.96	23.19	22.40	4.33	3.375	8.50	2.880	6.93	0.875	0.875	6318C3 or NU318	6316C3

NOTE

- Dimension "D" tolerance : +0.00inch - 0.03inch (143T-365T) ; +0.000inch - 0.06inch (404T-449T)
- Dimension "U" tolerance : +0.000inch - 0.005inch (143T-215T), +0.000inch - 0.001inch (254T-449T)
- Dimension "R" tolerance : +0.000inch - 0.015inch

Q'TY	DESCRIPTION	MATERIAL	DIMENSION	WEIGHT	PART NO.	REMARK	NO.
APPD BY	K.J. Kang	UNIT	INCH	SUBJECT	445T	CAD PROJ	FILE
Q.P CHK		SCALE	N/S	TITLE	OUTLINE		
CHKD BY		PROJEC'N	3 각법(3rd Angle)	REF. NO	A1118AA	Sheet No.	of
DSND BY	N.D.Lee	DATE	2011.01.12	DWG NO	350A1118AA	Revision No.	0