

본 도면은 현대중공업(주) 재산이며 복제할 수 없습니다 (취급유의)

THIS DRAWING IS PROPRIETARY TO HEECO. NO PART OF THIS DRAWING MAYBE REPRODUCED WITHOUT THE PERMISSION OF HHI.

		<h1>TEFC</h1> <h2>THREE PHASE INDUCTION MOTOR</h2>		<b>TYPE</b> LP, JP Cast iron frame
FRAME SIZE	OUTPUT(HP)	POLES	Hz	TIME RATING
405T			60	CONT

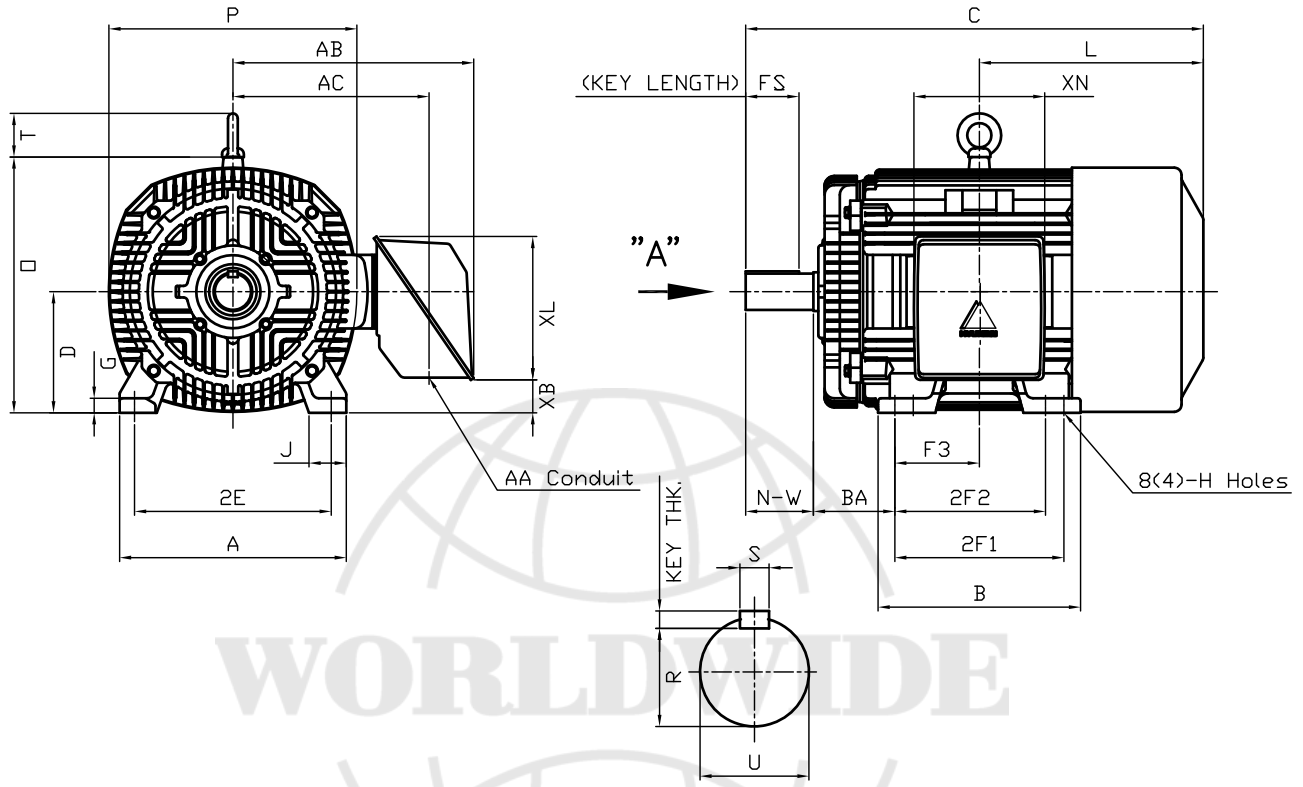

**DIMENSIONS**

**VIEW "A"**

M O U N T I N G									C O N D U I T B O X						APPROX. WGT.(LB)
A	B	2E	2F1	2F2	F3	G	J	H	AA	AB	AC	XB	XL	XN	
18.43	16.46	16.00	13.75	(12.25)	6.870	1.18	3.03	0.81	3.00	20.28	14.85	2.83	11.65	10.63	1110

O V E R A L L								S H A F T			KEY	BEARING		
BA	C	D	L	O	P	T	U	N-W	KEYWAY			THK.	DRIVE END	OPP. DRIVE END
									R	ES	S			
6.62	39.42	10.00	18.68	20.79	20.16	3.55	2.875	7.25	2.450	5.65	0.750	0.750	6316C3 or NU316	6313C3

**NOTE**

1. Dimension "D" tolerance : +0.00inch - 0.03inch (143T-365T) ; +0.000inch - 0.06inch (404T-449T)
2. Dimension "U" tolerance : +0.000inch - 0.005inch (143T-215T), +0.000inch - 0.001inch (254T-449T)
3. Dimension "R" tolerance : +0.000inch - 0.015inch

Q'TY	DESCRIPTION	MATERIAL	DIMENSION	WEIGHT	PART NO.	REMARK	NO.
APPD BY	K.J. Kang	UNIT	INCH	SUBJECT	405T	CAD PROJ 명 \ FILE 명	
Q.P CHK		SCALE	N/S	TITLE	OUTLINE		
CHKD BY		PROJEC'N	3 각법(3rd Angle)	REF. NO	A1116AA	Sheet No.	of
DSND BY	N.D.Lee	DATE	2011.01.12	DWG NO	350A1116AA	Revision No.	0