

본 도면은 현대중공업(주) 재산이므로
허가없이 복사할 수 없음 (취급유의)

THIS DRAWING IS PROPRIETARY TO HEECO. NO PART OF THIS DRAWING
MAYBE REPRODUCED WITHOUT THE PERMISSION OF HHI.

| | | | | |
|------------|------------|--|----|--|
| | | <h1>TEFC</h1> <h2>THREE PHASE INDUCTION MOTOR</h2> | | TYPE LP, JP Cast iron frame |
| FRAME SIZE | OUTPUT(HP) | POLES | Hz | TIME RATING |
| 449TS-4P | | | 60 | CONT |

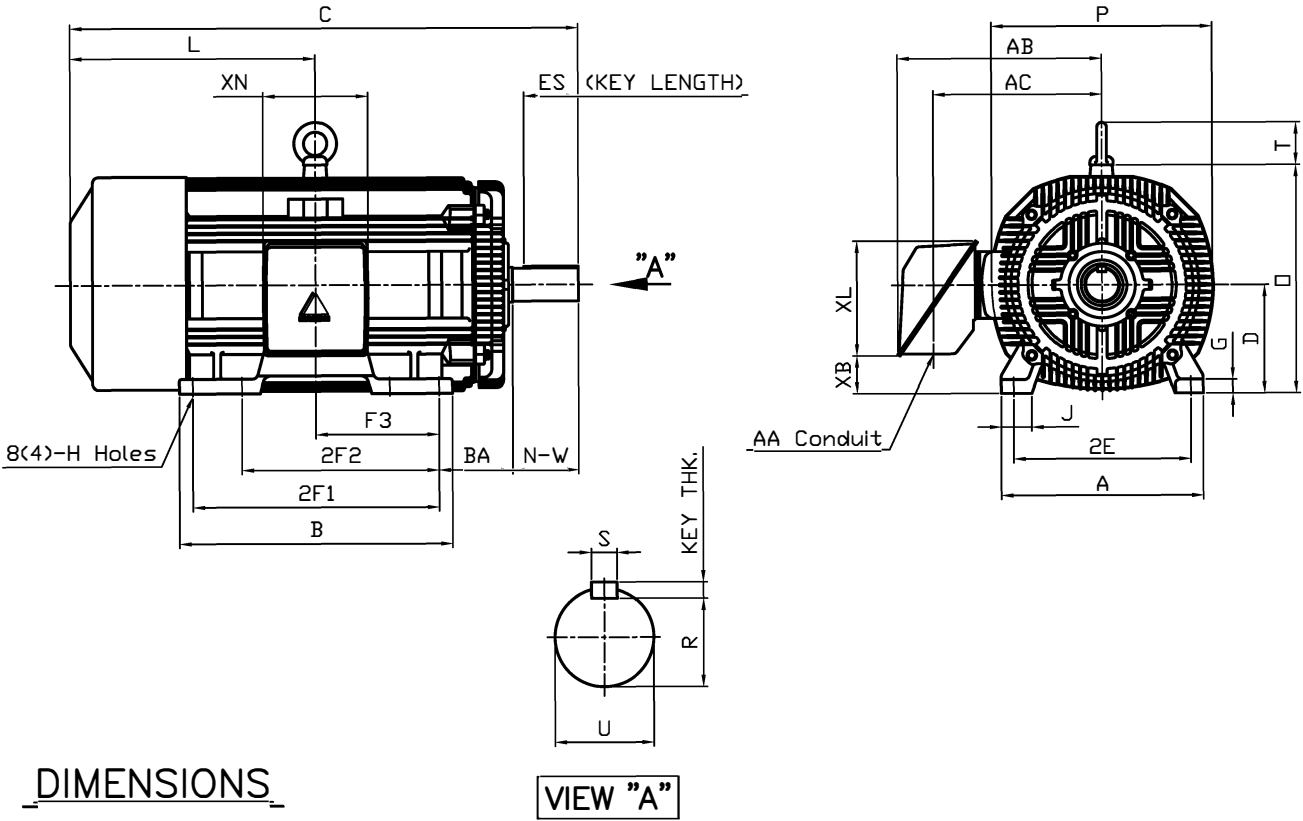

DIMENSIONS

VIEW "A"

| M O U N T I N G | | | | | | | | | C O N D U I T B O X | | | | | APPROX. WGT.(LB) | |
|-----------------|-------|-------|-------|---------|--------|------|------|------|---------------------|-------|-------|------|-------|------------------|------|
| A | B | 2E | 2F1 | 2F2 | F3 | G | J | H | AA | AB | AC | XB | XL | XN | |
| 20.51 | 27.72 | 18.00 | 25.00 | (20.00) | 12.500 | 1.42 | 3.07 | 0.81 | 3.00 | 21.26 | 18.03 | 3.83 | 11.65 | 10.63 | 2430 |

| O V E R A L L | | | | | | | S H A F T | | | KEY | BEARING | | | |
|---------------|-------|-------|-------|-------|-------|------|-----------|------|--------|------|---------|-------|-----------|----------------|
| BA | C | D | L | O | P | T | U | N-W | KEYWAY | | | THK. | DRIVE END | OPP. DRIVE END |
| | | | | | | | | | R | ES | S | | | |
| 7.50 | 50.08 | 11.00 | 25.33 | 23.19 | 22.40 | 4.33 | 2.375 | 4.75 | 2.021 | 3.03 | 0.625 | 0.625 | 6318C3 | 6316C3 |

NOTE

1. Dimension "D" tolerance : +0.00inch - 0.03inch (143T-365T) ; +0.000inch - 0.06inch (404T-449T)
2. Dimension "U" tolerance : +0.000inch - 0.005inch (143T-215T), +0.000inch - 0.001inch (254T-449T)
3. Dimension "R" tolerance : +0.000inch - 0.015inch

| Q'TY | DESCRIPTION | MATERIAL | DIMENSION | WEIGHT | PART NO. | REMARK | NO. |
|---------|-------------|----------|------------------|---------|----------|---------------|-----|
| APPD BY | K.J. KANG | UNIT | INCH | SUBJECT | 449TS | CAD PROJ FILE | |
| Q.P CHK | | SCALE | N/S | TITLE | OUTLINE | | |
| CHKD BY | | PROJEC'N | 3 각법 (3rd Angle) | | | | |
| DSND BY | N.D.LEE | DATE | 2011.02.09 | | | | |