



TEFC

THREE PHASE INDUCTION MOTOR

TYPE

LP, JP

CAST IRON FRAME

FRAME SIZE

OUTPUT(HP)

POLES

Hz

TIME RATING

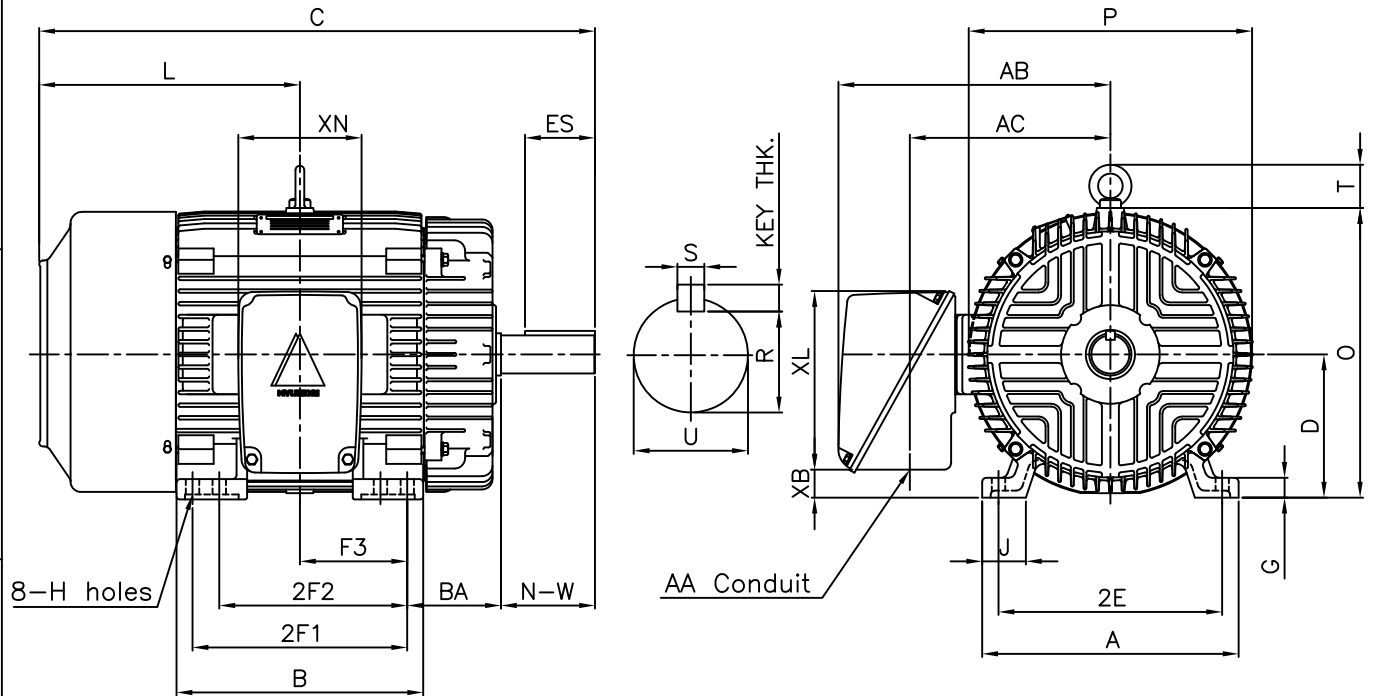

DIMENSIONS

M O U N T I N G									C O N D U I T B O X						A P P R O X . W G T . (L B)	
A	B	2E	2F1 ⁵⁾	2F2 ⁴⁾	F3	G	J	H	AA	AB	AC	XB	XL	XN	324T	326T
14.33	13.78	12.50	12.00	10.50	6.00	1.11	2.36	0.66	2.00	15.20	11.21	1.57	10.16	7.01	550	560

O V E R A L L							S H A F T					K E Y T H K .	B E A R I N G	
BA	C	D	L	O	P	T	U	N-W	K E Y W A Y				D R I V E E N D	O P P . D R I V E E N D
									R	ES	S			
5.25	31.07	8.00	14.57	16.19	15.84	2.41	2.125	5.25	1.845	3.91	0.500	0.500	6313ZC3	6211ZC3

NOTE

- 1.Dimension "D" tolerance : +0.00inch - 0.03inch
- 2.Dimension "U" tolerance : +0.000inch - 0.001inch
- 3.Dimension "R" tolerance : +0.000inch - 0.015inch
- 4.Location of holes for 324T frame
- 5.Location of holes for 326T frame

APPD BY	KIM.Y.S	UNIT	INCH	SUBJECT	NEMA 324T/326T	CAD PROJ \ FILE	XSMOUTN\A1112AA
CHKD BY	KO.S.H	SCALE	1/12			TITLE	OUTLINE
CHKD BY		PROJEC'N	3rd Angle	REF. NO	A1112AA	Sheet No.	of
DSND BY	LEE KWANG SOO	DATE	2004.04.02	DWG NO	350A1112AA	Revision No.	0

