

본 도면은 현대중공업(주) 재산이므로
허가없이 복사할 수 없음 (취급유의)

THIS DRAWING IS PROPRIETARY TO HEECO. NO PART OF THIS DRAWING
MAYBE REPRODUCED WITHOUT THE PERMISSION OF HHI.

		<h1>TEFC</h1> <h2>THREE PHASE INDUCTION MOTOR</h2>		TYPE LP, JP Cast iron frame
FRAME SIZE	OUTPUT(HP)	POLES	Hz	TIME RATING
445TS-4P			60	CONT

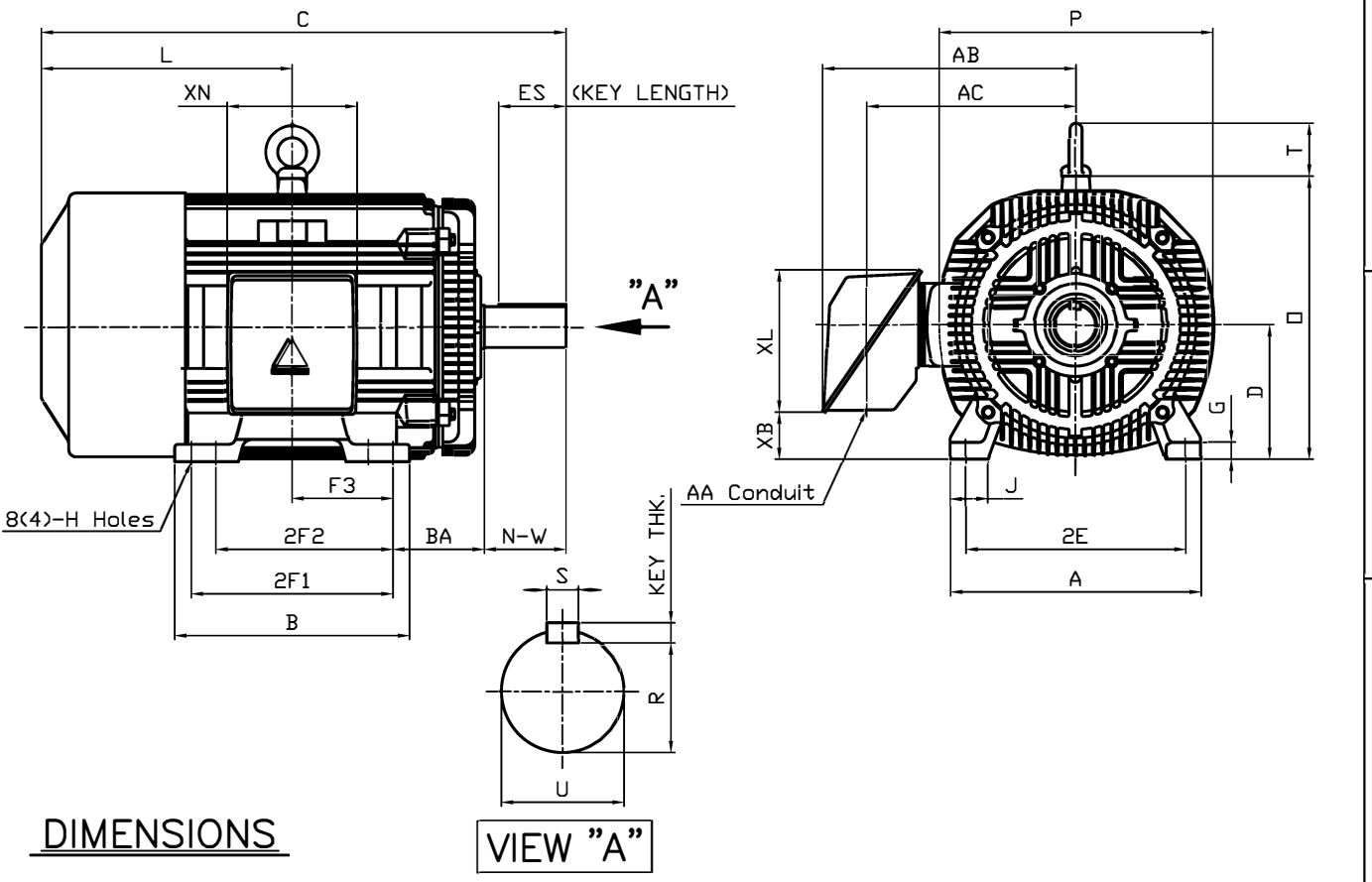

DIMENSIONS

VIEW "A"

M O U N T I N G									C O N D U I T B O X					APPROX. WGT.(LB)	
A	B	2E	2F1	2F2	F3	G	J	H	AA	AB	AC	XB	XL	XN	
20.51	19.21	18.00	16.50	(14.50)	8.248	1.42	3.07	0.81	3.00	21.26	18.03	3.83	11.65	10.63	1770

O V E R A L L							S H A F T			KEY	BEARING			
BA	C	D	L	O	P	T	U	N- W	KEYWAY			THK.	DRIVE END	OPP. DRIVE END
									R	ES	S			
7.50	41.46	11.00	20.96	23.19	22.40	4.33	2.375	4.75	2.021	3.03	0.625	0.625	6318C3	6316C3

NOTE

- Dimension "D" tolerance : +0.00inch - 0.03inch (143T-365T) ; +0.000inch - 0.06inch (404T-449T)
- Dimension "U" tolerance : +0.000inch - 0.005inch (143T-215T), +0.000inch - 0.001inch (254T-449T)
- Dimension "R" tolerance : +0.000inch - 0.015inch

Q'TY	DESCRIPTION	MATERIAL	DIMENSION	WEIGHT	PART NO.	REMARK	NO.
APPD BY	K.J. KANG	UNIT	INCH	SUBJECT	445TS	CAD PROJ FILE	
Q.P CHK		SCALE	N/S				
CHKD BY		PROJEC'N	3 각법(3rd Angle)	<h1>OUTLINE</h1>			
DSND BY	N.D.LEE	DATE	2011.02.09				
				REF. NO	A1118BA	Sheet No.	of
				DWG NO	350A1118BA	Revision No.	0