

4

3

2

1

REV	ECO	REV BY	DATE	APPD	DATE
D	0025215	G. RODRIGUEZ	04-04-15	DANIEL MUÑOZ	04-04-15

GROUP	TYPE	FRAME	"C"	(BS)	(XA)	(XG)	(XH)	(XN)
03394503-001	CS	L56	13.36[339.3]	3.55[90.2]	2.01[51.1]	3.97[100.8]	4.06[103.1]	5.20[132.1]
03394503-002	CS	J56	12.24[310.9]	2.43[61.7]	1.64[41.7]	2.84[72.1]	4.08[103.1]	4.87[123.7]
03394503-003	CS	K56	12.61[320.3]	2.80[71.1]	1.64[41.7]	3.22[81.8]	4.06[103.1]	4.81[122.2]

ALL DIMENSION SHOWN IN PARENTHESIS ARE REFERENCE DIMENSIONS. ALL OTHER DIMENSIONS ARE TOLERANCED PER THE FOLLOWING CHART UNLESS OTHERWISE SPECIFIED.

"C" DIM. = ±.055[±1.40]
 SHAFT EXT. = ±.034[±.86]
 LEAD LENGTHS EXTENDED = ±1.00[±25.4]
 THRU-BOLTS = ±.050[±1.27]
 ANGULAR DIMS. = ±2 DEGS.

D

D

C

C

B

B

A

A

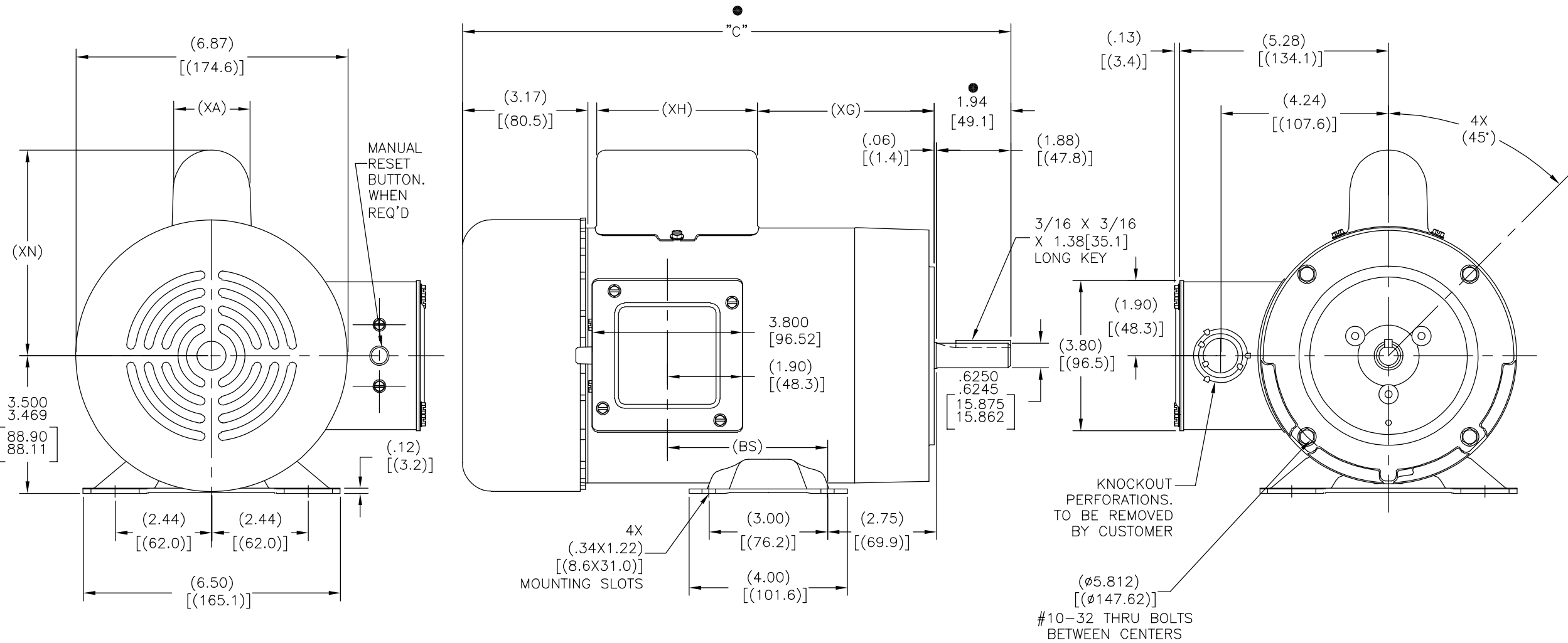

GEOMETRIC CHARACTERISTICS & SYMBOLS

- FLATNESS
- STRAIGHTNESS
- ∠ ANGULARITY
- ⊥ PERPENDICULARITY (SQUARENESS)
- ∥ PARALLELISM
- ROUNDNESS (CIRCULARITY)
- ⊘ CYLINDRICITY
- △ PROFILE OF ANY SURFACE
- ∧ PROFILE OF ANY LINE
- ↗ RUNOUT
- ⊕ TRUE POSITION
- ⊙ CONCENTRICITY
- ≡ SYMMETRY

ASME Y14.5M 1994

UNLESS OTHERWISE SPECIFIED DIM. TOLERANCES ARE AS FOLLOWS:

INCH	±.1	±.02	±.005	±.0005
mm	±0.5	±0.13	±0.013	

ANG. ±.50 DEG
 REMOVE BURRS & BREAK SHARP EDGES:
 INCH .003-.015 mm 0.1-0.4
 CORNER FILLETS TO:
 INCH .020 mm 0.5
 MACHINE SURFACES:
 INCH 125 mm 3.2

METRIC DIMS. SHOWN IN [BRACKETS]

DR BY:	RALVAR	02-08-2005
APPD:	RARMEN	02-08-2005
THIRD ANGLE PROJECTION	EDS DATE 11-11-2011 FORMAT REV G	
CONFIDENTIAL: THIS DRAWING AND ITS INFORMATION ARE THE EXCLUSIVE AND CONFIDENTIAL PROPERTY OF REGAL-BELOIT CORPORATION AND ARE NOT TO BE DISCLOSED, DUPLICATED, DISTRIBUTED OR OTHERWISE USED WITHOUT THE WRITTEN CONSENT OF REGAL-BELOIT CORPORATION. -ALL RIGHTS RESERVED.		

REGAL-BELOIT CORPORATION	
DESCRIPTION OUTLINE	
SIZE C	DWG NO 03394503
SCALE NONE	SHEET 1

4

3

2

1

4

3

2

1

REVISION:	ECO	REVISADO POR:	FECHA:	APROBADO POR:	FECHA:
D	0025215	G. RODRIGUEZ	04-04-15	DANIEL MUÑOZ	04-04-15

GRUPO	CLASE	CARCAZA	"C"	(BS)	(XA)	(XG)	(XH)	(XN)
03394503-001	CS	L56	13.36[339.3]	3.55[90.2]	2.01[51.1]	3.97[100.8]	4.06[103.1]	5.20[132.1]
03394503-002	CS	J56	12.24[310.9]	2.43[61.7]	1.64[41.7]	2.84[72.1]	4.08[103.1]	4.87[123.7]
03394503-003	CS	K56	12.61[320.3]	2.80[71.1]	1.64[41.7]	3.22[81.8]	4.06[103.1]	4.81[122.2]

TODAS LAS DIMENSIONES MOSTRADAS ENTRE PARENTESIS SON DIMENSIONES DE REFERENCIA. TODAS LAS DEMAS DIMENSIONES MANEJAN UNA TOLERANCIA QUE SE MUESTRA EN LA SIGUIENTE TABLA A MENOS DE QUE SE ESPECIFIQUE LO CONTRARIO.

DIMENSION DE "C" = ±.055[±1.40]
 EXTENSION DE FLECHA = ±.034[±.86]
 LARGO DE CABLES EXTENDIDOS = ±1.00[±25.4]
 PERNO PASADO = ±.050[±1.27]
 DIMENSION ANGULAR = ±2' GRADOS

D

D

C

C

B

B

A

A

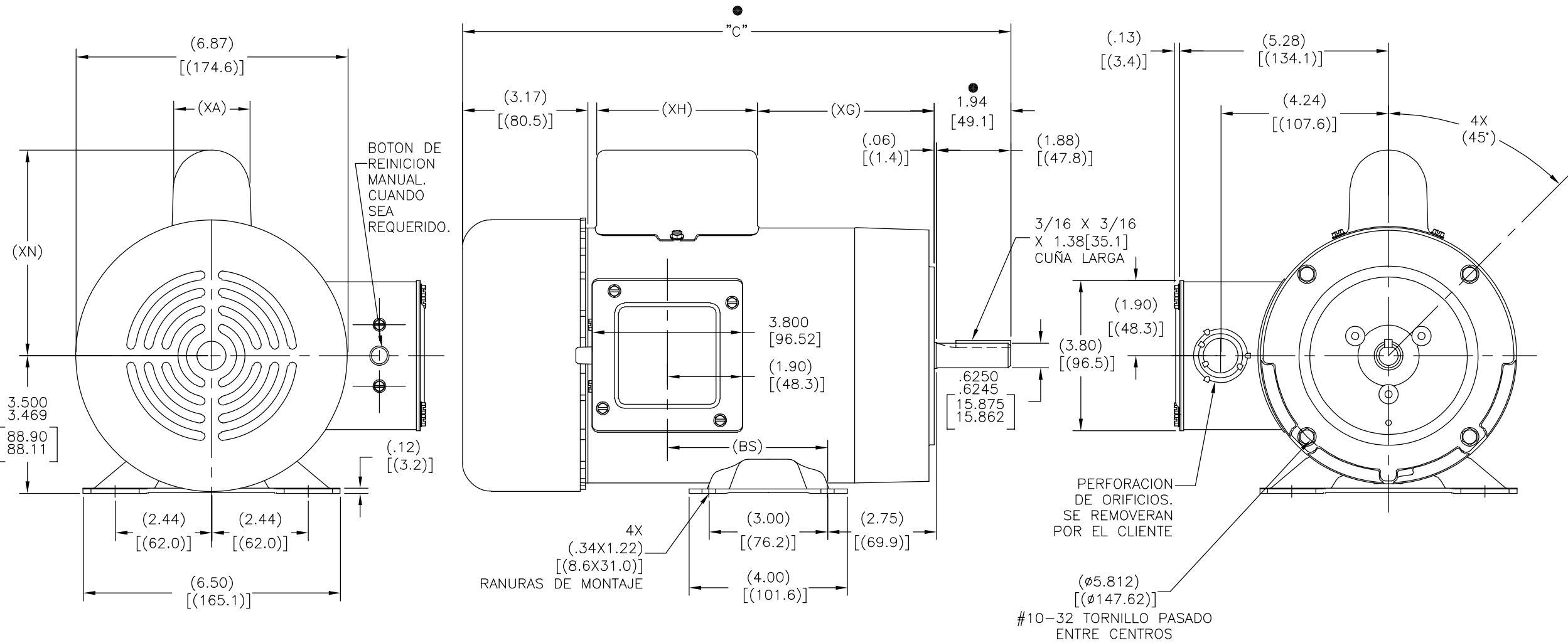

● = DIMENSION CRITICA

CARACTERISTICAS DE GEOMETRIA Y SIMBOLOS
 ▭ PLANICIDAD
 - RECTITUD
 < ANGULARIDAD
 ⊥ PERPENDICULARIDAD (A ESQUADRA)
 // PARALELISMO
 ○ REDONDEZ (CIRCULARIDAD)
 ∅ CILINDRICIDAD
 △ PERFIL DE CUALQUIER SUPERFICIE
 ∩ PERFIL DE CUALQUIER LINEA
 ↗ VARIACION
 ⊕ POSICION REAL
 ⊙ CONCENTRICIDAD
 = SIMETRIA

A MENOS QUE SE ESPECIFIQUE DE OTRA MANERA, LAS TOLERANCIAS DE LAS DIMS; SON LAS SIGUIENTES:
 PULG ±.1 ±.02 ±.005 ±.0005
 mm ±0.5 ±0.13 ±0.013
 ANG. ± 50 GRADOS
 ELIMINAR REBABAS Y ORILLAS FILOSAS DEL BORDE.
 PULG .003-.015 mm 0.1-0.4
 FILETEAR ESQUINA: PULG .020 mm 0.5
 MAQUINAR SUPERFICIES
 PULG 125 mm .32

DIBUJADO POR: RALVAR 02-08-2005
 APROBADO POR: RARMEN 02-08-2005
 TERCER ANGULO DE PROYECCION
 CONFIDENCIAL: ESTE DIBUJO Y SU INFORMACION SON PROPIEDAD DE USO EXCLUSIVO Y CONFIDENCIAL DE REGAL-BELOIT CORPORATION. Y NO DEBERAN SER REVELADOS, DUPLICADOS, DISTRIBUIDOS O USARSE DE OTRA MANERA SIN EL CONSENTIMIENTO ESCRITO DE REGAL-BELOIT CORPORATION. -TODOS LOS DERECHOS RESERVADOS.

REGAL-BELOIT CORPORATION
 DESCRIPCION: OUTLINE
 TAMAÑO: C NUMERO DE DIBUJO: 03394503
 ESCALA: NONE HOJA: 1

4

3

2

1

4

3

2

1

版本	ECO	编制	日期	批准	日期
D	0025215	G. RODRIGUEZ	04-04-15	DANIEL MUÑOZ	04-04-15

			"C"	(BS)	(XA)	(XG)	(XH)	(XN)
03394503-001	CS	L56	13.36[339.3]	3.55[90.2]	2.01[51.1]	3.97[100.8]	4.06[103.1]	5.20[132.1]
03394503-002	CS	J56	12.24[310.9]	2.43[61.7]	1.64[41.7]	2.84[72.1]	4.08[103.1]	4.87[123.7]
03394503-003	CS	K56	12.61[320.3]	2.80[71.1]	1.64[41.7]	3.22[81.8]	4.06[103.1]	4.81[122.2]

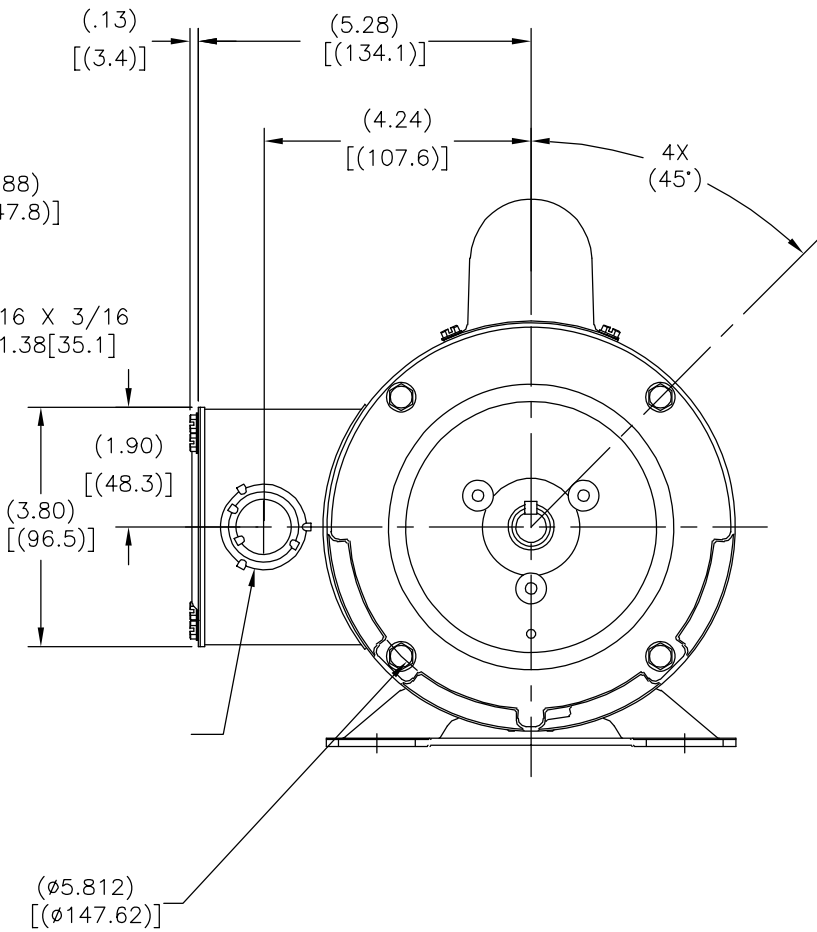
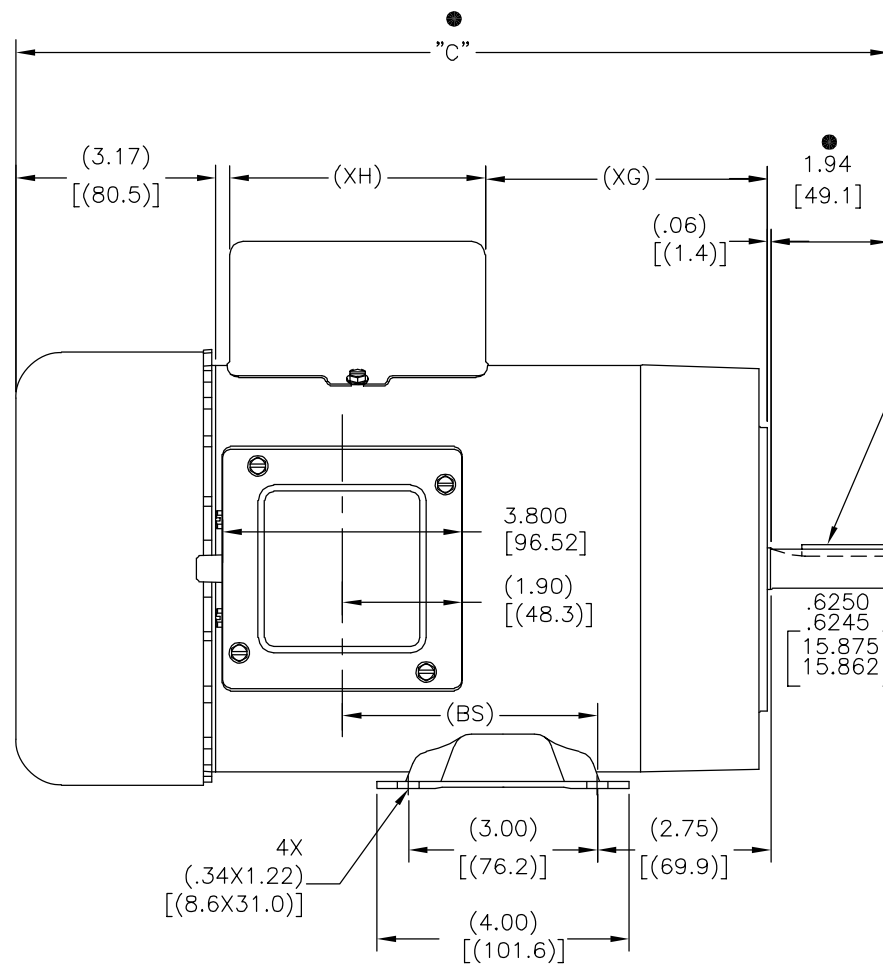
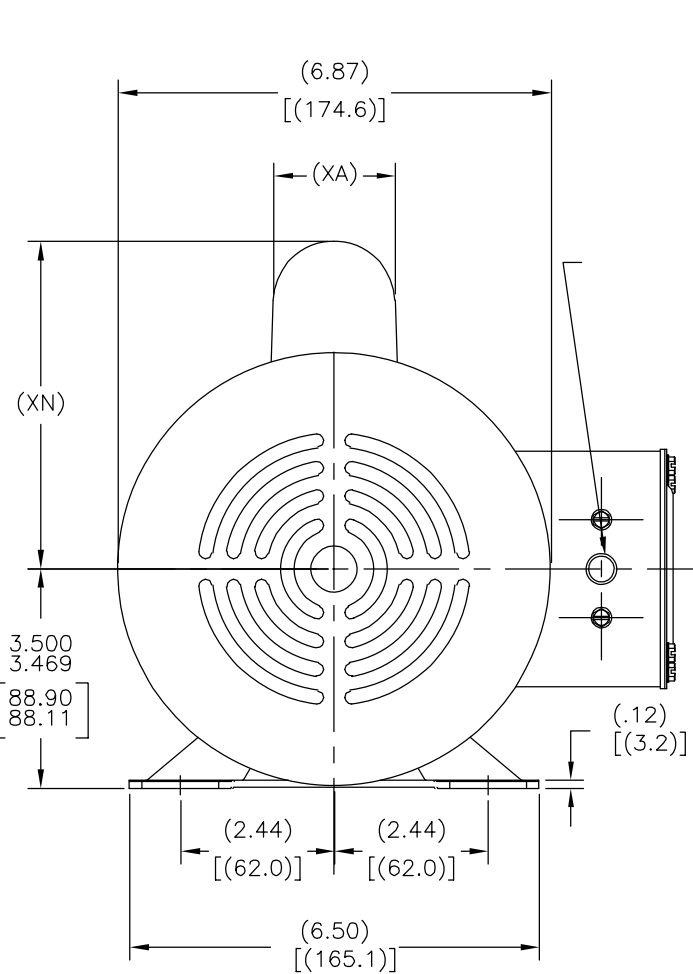

形位公差	除另有注明
□ 平面度	尺寸公差如下:
— 直线度	英寸 X XX XXX XXXX
∠ 倾斜度	英寸 ±.1 ±.02 ±.005 ±.0005
⊥ 垂直度	毫米 ±0.5 ±0.13 ±0.013
// 平行度	角度 ±.50 度
○ 圆度	清理毛刺和尖棱
⊙ 圆柱度	英寸 .003-.015 毫米 0.1-0.4
⊖ 内圆角	内圆角
△ 面轮廓度	英寸 .020 毫米 0.5
∩ 线轮廓度	表面粗糙度
⤴ 圆跳动	英制 125 米制 3.2
⊕ 位置度	米制尺寸显示在 []
⊗ 同轴度	
≡ 对称度	

ASME Y14.5M 1994

除另有注明	尺寸公差如下:
英寸 X XX XXX XXXX	
英寸 ±.1 ±.02 ±.005 ±.0005	
毫米 ±0.5 ±0.13 ±0.013	
角度 ±.50 度	
清理毛刺和尖棱	
英寸 .003-.015 毫米 0.1-0.4	
内圆角	
英寸 .020 毫米 0.5	
表面粗糙度	
英制 125 米制 3.2	
米制尺寸显示在 []	

绘图:	RALVAR	02-08-2005
批准:	RARMEN	02-08-2005
第三角投影		图纸格式发布日期 11-11-2011 图纸格式版本 G
机密: 本图纸及相关信息所有权归REGAL-BELOIT CORPORATION 未经REGAL-BELOIT CORPORATION书面授权, 不得泄露、 复制、传播或作其他用途。—版权所有		

名称	OUTLINE
图幅	C
图号	03394503
比例	NONE
页号	1

4

3

2

1