

4

3

2

1

REV	ECO	REV BY	DATE	APPD	DATE
F	0025361	L. BERNAL	04-12-2012	D. BALDERRAMA	04-12-2012

GROUP	TYPE	FRAME	"C"	(BS)	(XA)	(XG)	(XH)	(XN)
189910-01	CS	L56	13.36[339.3]	3.55[90.2]	2.01[51.1]	3.97[100.8]	4.06[103.1]	5.20[132.1]
189910-02	CS	J56	12.24[310.9]	2.43[61.7]	1.64[41.7]	2.84[72.1]	4.08[103.6]	4.87[123.7]
189910-03	CS	K56	12.61[320.3]	2.80[71.1]	1.64[41.7]	3.22[81.8]	4.06[103.1]	4.81[122.2]

ALL DIMENSION SHOWN IN PARENTHESIS ARE REFERENCE DIMENSIONS. ALL OTHER DIMENSIONS ARE TOLERANCED PER THE FOLLOWING CHART UNLESS OTHERWISE SPECIFIED.

"C" DIM. = ±.055[±1.40]
 SHAFT EXT. = ±.034[±.86]
 LEAD LENGTHS EXTENDED = ±1.00[±25.4]
 THRU-BOLTS = ±.050[±1.27]
 ANGULAR DIMS. = ±2 DEGS.

D

D

C

C

B

B

A

A

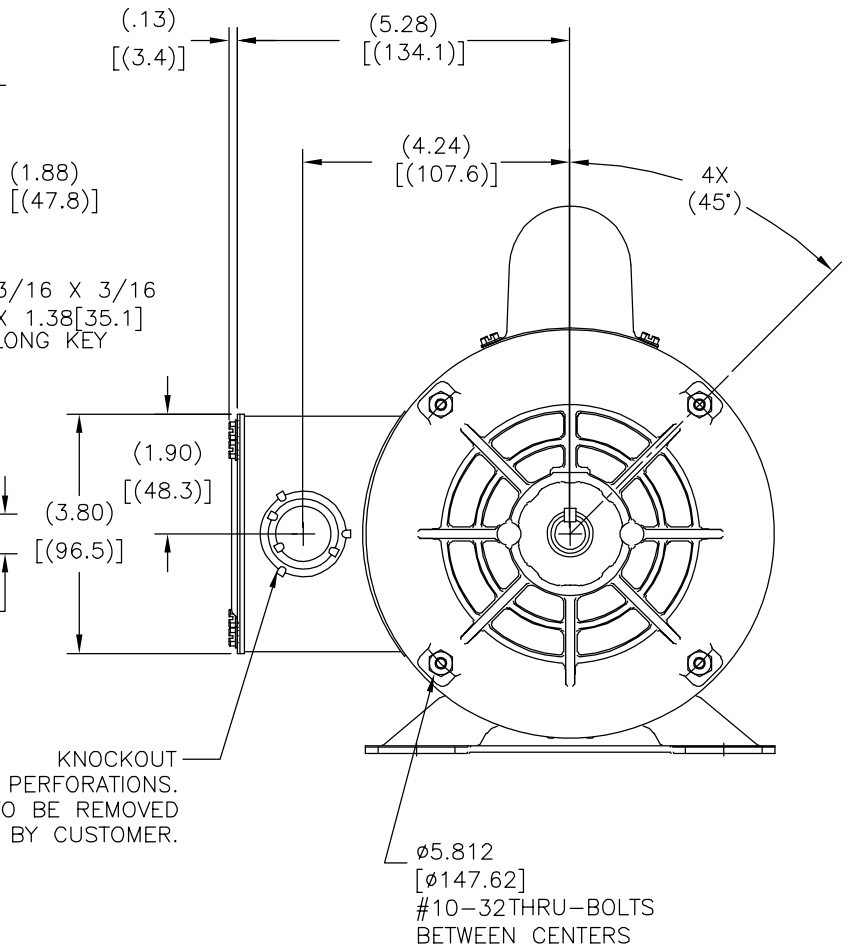
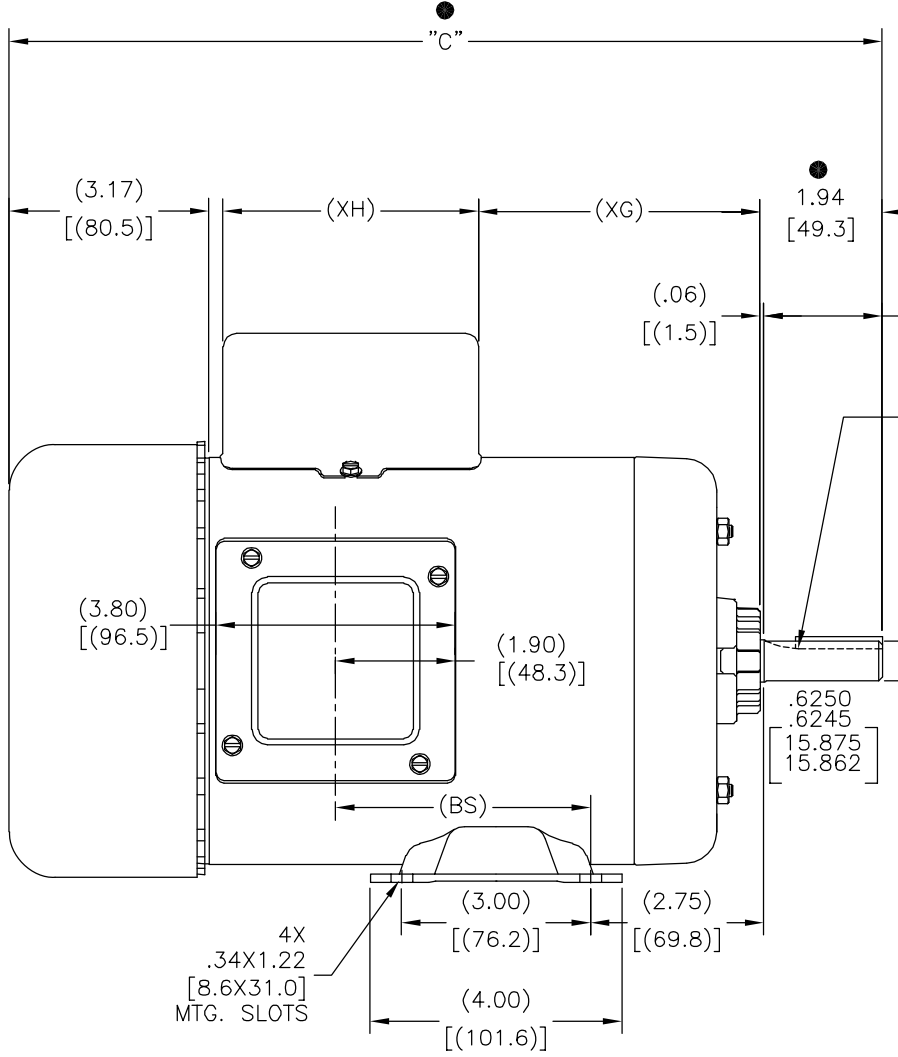
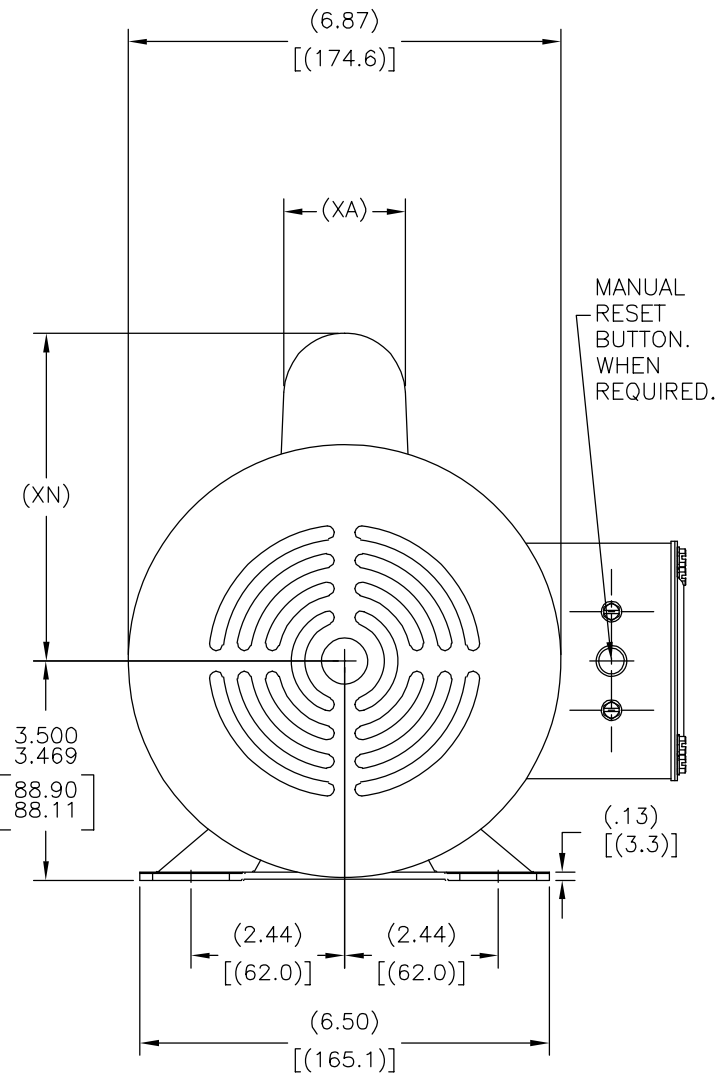

GEOMETRIC CHARACTERISTICS & SYMBOLS

- FLATNESS
- STRAIGHTNESS
- ∠ ANGULARITY
- ⊥ PERPENDICULARITY (SQUARENESS)
- ∥ PARALLELISM
- ROUNDNESS (CIRCULARITY)
- ⊘ CYLINDRICITY
- △ PROFILE OF ANY SURFACE
- ∩ PROFILE OF ANY LINE
- ↗ RUNOUT
- ⊕ TRUE POSITION
- ⊙ CONCENTRICITY
- ≡ SYMMETRY

ASME Y14.5M 1994

UNLESS OTHERWISE SPECIFIED DIM. TOLERANCES ARE AS FOLLOWS:

INCH X XX XXX XXXX
 ±.1 ±.02 ±.005 ±.0005
 mm ±0.5 ±0.13 ±0.013

ANG. ±.50 DEG
 REMOVE BURRS & BREAK SHARP EDGES:
 INCH .003-.015 mm 0.1-0.4

CORNER FILLETS TO:
 INCH .020 mm 0.5

MACHINE SURFACES:
 INCH 125 mm 3.2

METRIC DIMS. SHOWN IN [BRACKETS]

DR BY:	DAVHOL	10-04-1999
APPD:	N.LONG	10-04-1999
THIRD ANGLE PROJECTION		EDS DATE 11-11-2011 FORMAT REV G
CONFIDENTIAL: THIS DRAWING AND ITS INFORMATION ARE THE EXCLUSIVE AND CONFIDENTIAL PROPERTY OF REGAL-BELOIT CORPORATION AND ARE NOT TO BE DISCLOSED, DUPLICATED, DISTRIBUTED OR OTHERWISE USED WITHOUT THE WRITTEN CONSENT OF REGAL-BELOIT CORPORATION. -ALL RIGHTS RESERVED.		

DESCRIPTION OUTLINE	
SIZE C	DWG NO 189910
SCALE NONE	SHEET 1

4

3

2

1

4

3

2

1

REVISION:	ECO	REVISADO POR:	FECHA:	APROBADO POR:	FECHA:
F	0025361	L. BERNAL	04-12-2012	D. BALDERRAMA	04-12-2012

GRUPO	CLASE	CARCAZA	"C"	(BS)	(XA)	(XG)	(XH)	(XN)
189910-01	CS	L56	13.36[339.3]	3.55[90.2]	2.01[51.1]	3.97[100.8]	4.06[103.1]	5.20[132.1]
189910-02	CS	J56	12.24[310.9]	2.43[61.7]	1.64[41.7]	2.84[72.1]	4.08[103.6]	4.87[123.7]
189910-03	CS	K56	12.61[320.3]	2.80[71.1]	1.64[41.7]	3.22[81.8]	4.06[103.1]	4.81[122.2]

TODAS LAS DIMENSIONES MOSTRADAS ENTRE PARENTESIS SON DIMENSIONES DE REFERENCIA. TODAS LAS DEMAS DIMENSIONES MANEJAN UNA TOLERANCIA QUE SE MUESTRA EN LA SIGUIENTE TABLA A MENOS DE QUE SE ESPECIFIQUE LO CONTRARIO.

DIMENSION DE "C"	= ±.055[±1.40]
EXTENSION DE FLECHA	= ±.034[±.86]
LARGO DE CABLES EXTENDIDOS	= ±1.00[±25.4]
PERNO PASADO	= ±.050[±1.27]
DIMENSION ANGULAR	= ±2° GRADOS

D

D

C

C

B

B

A

A

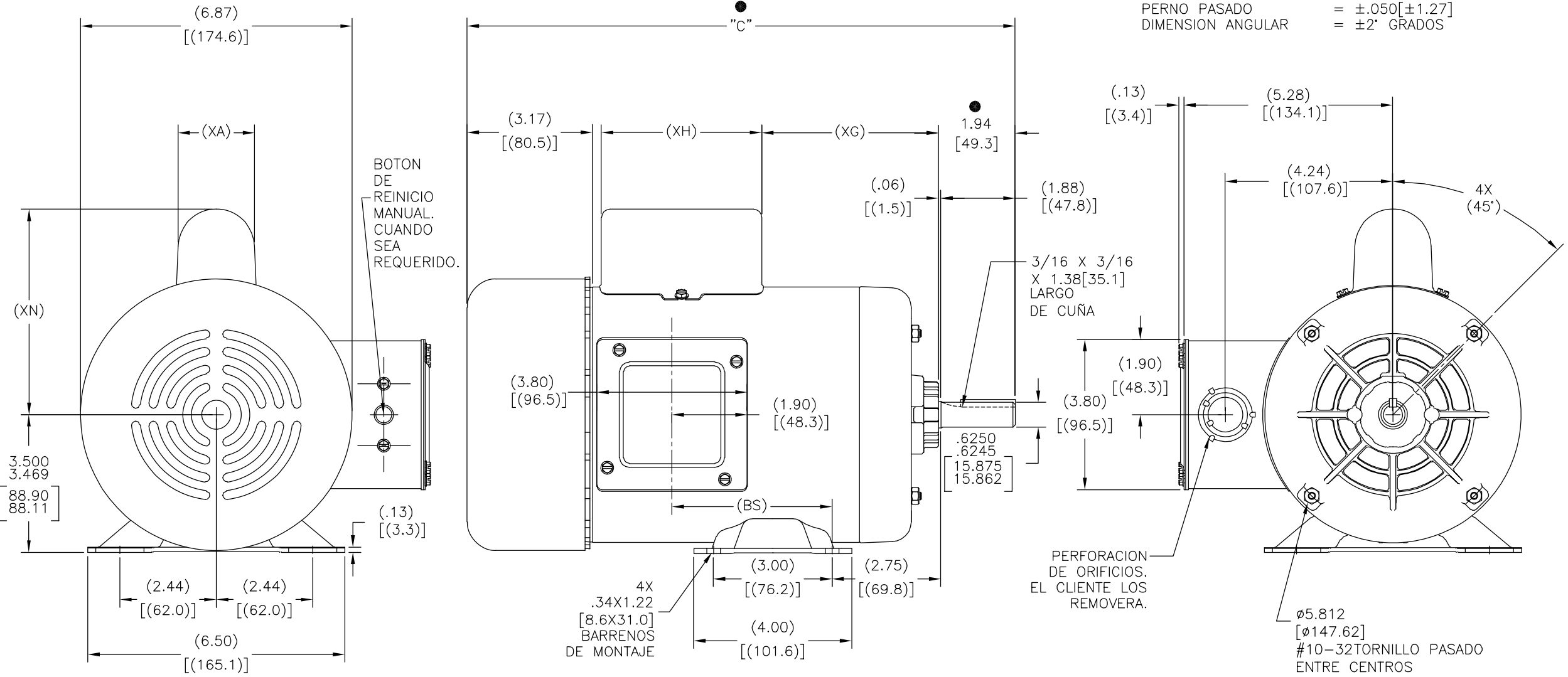

CARACTERISTICAS DE GEOMETRIA Y SIMBOLOS

- PLANICIDAD
- RECTITUD
- ∠ ANGULARIDAD
- ⊥ PERPENDICULARIDAD (A ESQUADRA)
- // PARALELISMO
- REDONDEZ (CIRCULARIDAD)
- ⊘ CILINDRICIDAD
- △ PERFIL DE CUALQUIER SUPERFICIE
- ∧ PERFIL DE CUALQUIER LINEA
- ∧ VARIACION
- ⊕ POSICION REAL
- ◎ CONCENTRICIDAD
- = SIMETRIA

ASME Y14.5M 1994

A MENOS QUE SE ESPECIFIQUE DE OTRA MANERA, LAS TOLERANCIAS DE LAS DIMS; SON LAS SIGUIENTES:

PULG ±.1 ±.02 ±.005 ±.0005
 mm ±0.5 ±0.13 ±0.013

ANG. ± 50 GRADOS

ELIMINAR REBABAS Y ORILLAS FILOSAS DEL BORDE.

PULG .003-.015 mm 0.1-0.4

FILETEAR ESQUINA: PULG .020 mm 0.5

MAQUINAR SUPERFICIES

PULG 125 mm .32

DIMS METRICAS MOSTRADAS [PARENTESIS]

DIBUJADO POR:	DAVHOL	10-04-1999
APROBADO POR:	N.LONG	10-04-1999
TERCER ANGULO DE PROYECCION	⊕	FECHA EDS: 11-11-2011 REV. FORMATO: G
CONFIDENCIAL: ESTE DIBUJO Y SU INFORMACION SON PROPIEDAD DE USO EXCLUSIVO Y CONFIDENCIAL DE REGAL-BELOIT CORPORATION. Y NO DEBERAN SER REVELADOS, DUPLICADOS, DISTRIBUIDOS O USARSE DE OTRA MANERA SIN EL CONSENTIMIENTO ESCRITO DE REGAL-BELOIT CORPORATION. -TODOS LOS DERECHOS RESERVADOS.		

REGAL-BELOIT CORPORATION	
DESCRIPCION: OUTLINE	
TAMAÑO: C	NUMERO DE DIBUJO: 189910
ESCALA: NONE	HOJA: 1

4

3

2

1

4

3

2

1

版本	ECO	编制	日期	批准	日期
F	0025361	L. BERNAL	04-12-2012	D. BALDERRAMA	04-12-2012

			"C"	(BS)	(XA)	(XG)	(XH)	(XN)
189910-01	CS	L56	13.36[339.3]	3.55[90.2]	2.01[51.1]	3.97[100.8]	4.06[103.1]	5.20[132.1]
189910-02	CS	J56	12.24[310.9]	2.43[61.7]	1.64[41.7]	2.84[72.1]	4.08[103.6]	4.87[123.7]
189910-03	CS	K56	12.61[320.3]	2.80[71.1]	1.64[41.7]	3.22[81.8]	4.06[103.1]	4.81[122.2]

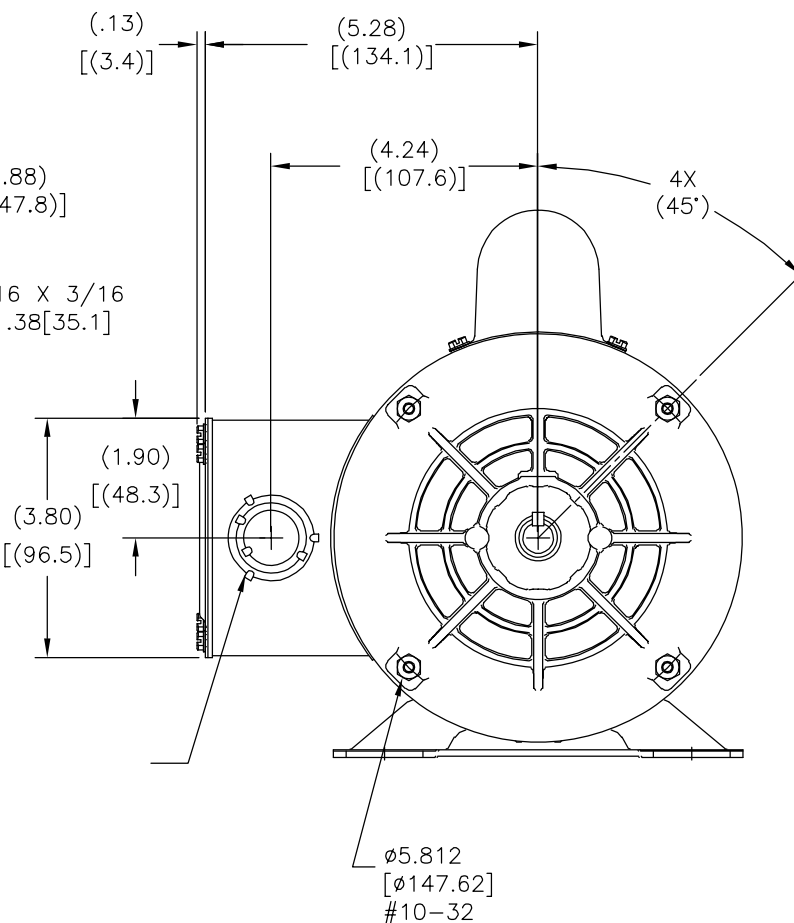
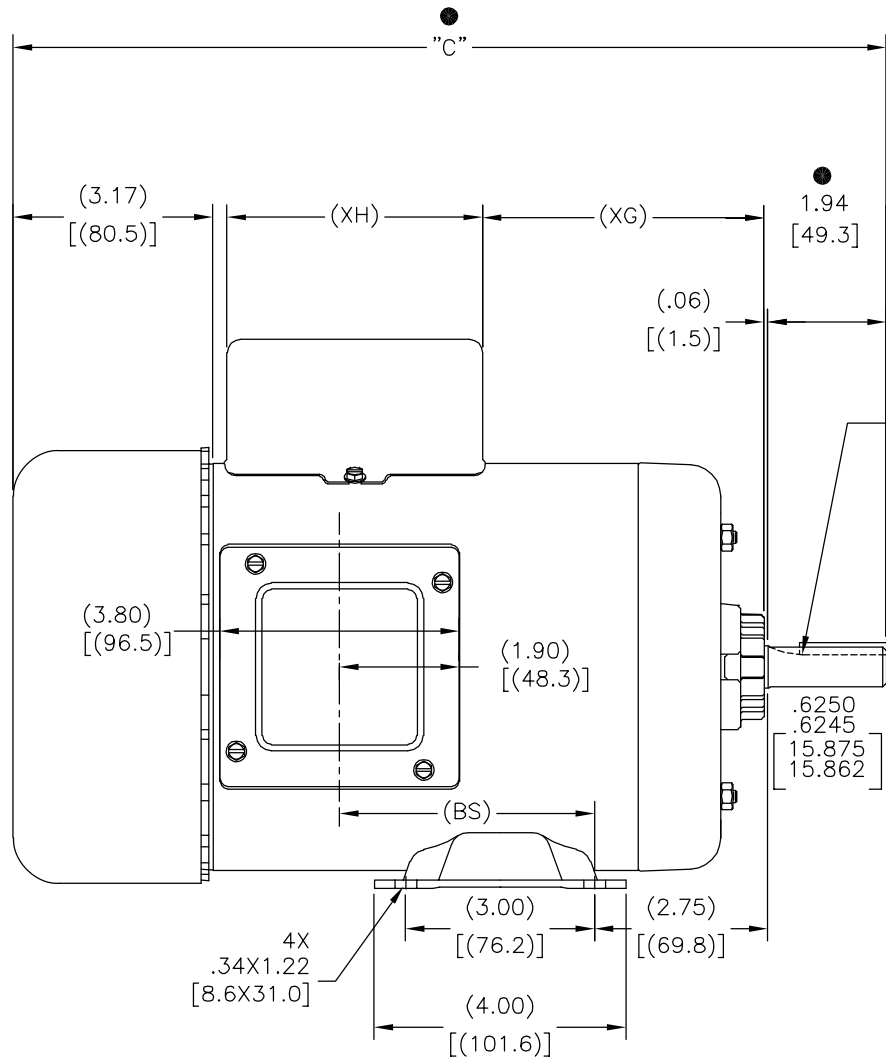
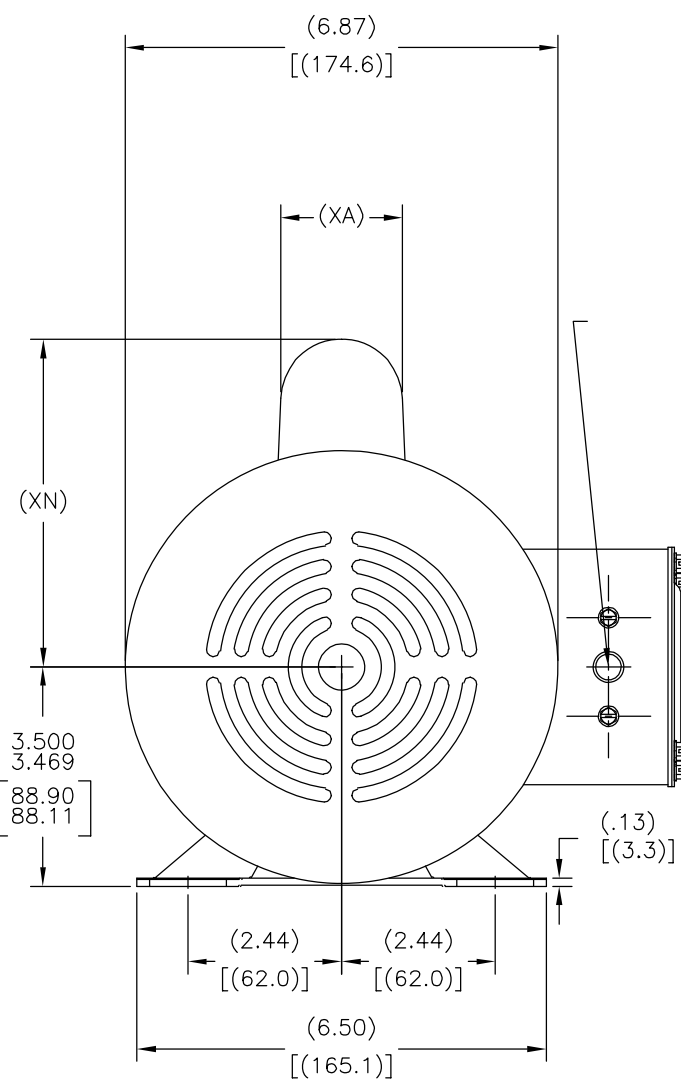

形位公差	除另有注明
□ 平面度	尺寸公差如下:
— 直线度	英寸 X XX XXX XXXX
∠ 倾斜度	英寸 ±.1 ±.02 ±.005 ±.0005
⊥ 垂直度	毫米 ±0.5 ±0.13 ±0.013
// 平行度	角度 ±.50 度
○ 圆度	清理毛刺和尖棱
⊘ 圆柱度	英寸 .003-.015 毫米 0.1-0.4
⊙ 面轮廓度	内圆角
⌒ 线轮廓度	英寸 .020 毫米 0.5
⌒ 圆跳动	表面粗糙度
⊕ 位置度	英制 125 米制 3.2
⊙ 同轴度	米制尺寸显示在 []
≡ 对称度	

ASME Y14.5M 1994

绘图:	DAVHOL	10-04-1999
批准:	N.LONG	10-04-1999
第三角投影		图纸格式发布日期 11-11-2011 图纸格式版本 G
机密: 本图纸及相关信息所有权归REGAL-BELOIT CORPORATION. 未经REGAL-BELOIT CORPORATION书面授权, 不得泄露、复制、传播或作其他用途。—版权所有		



名称	OUTLINE	
图幅	C	图号 189910
比例	NONE	页号 1

4

3

2

1