

REV	ECO	REV BY	DATE	APPD	DATE
D	0025402	O. CARVAJAL	04-13-2012	D. BALDERRAMA	04-13-2012

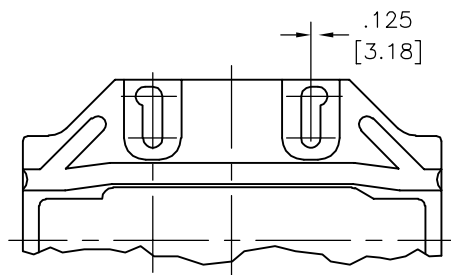
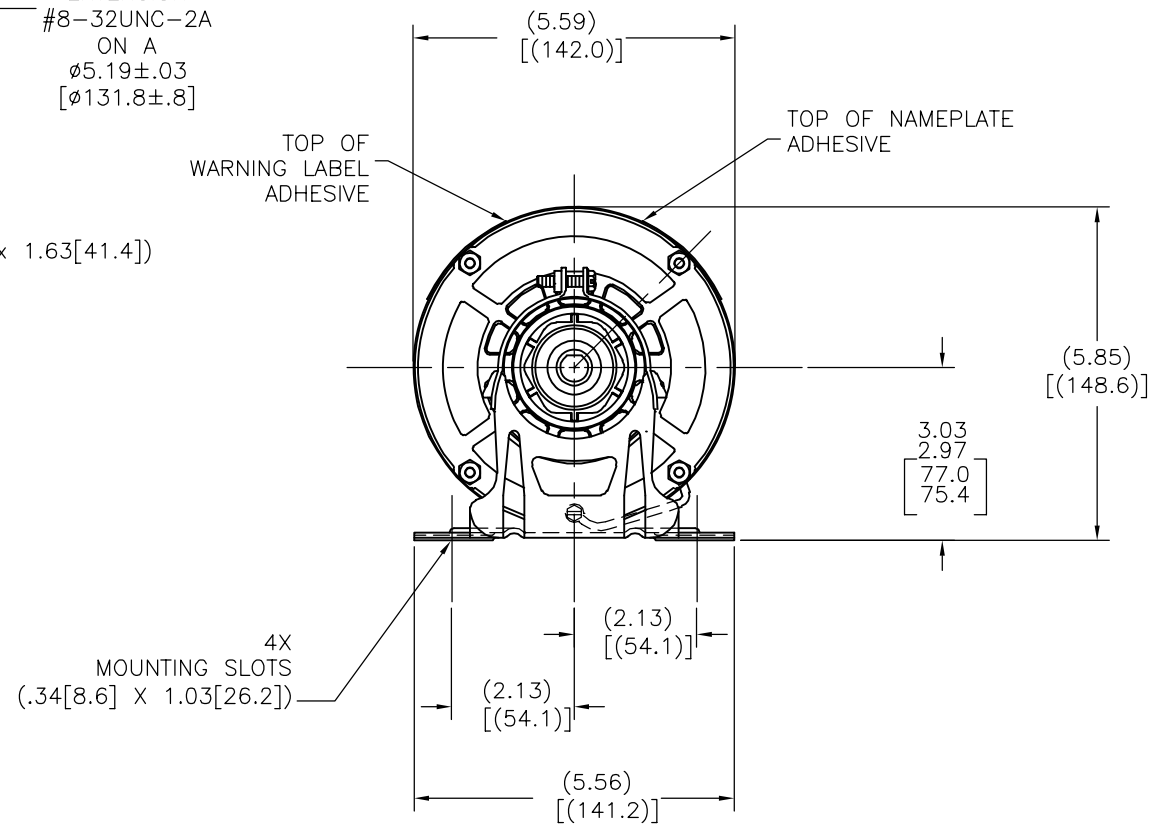
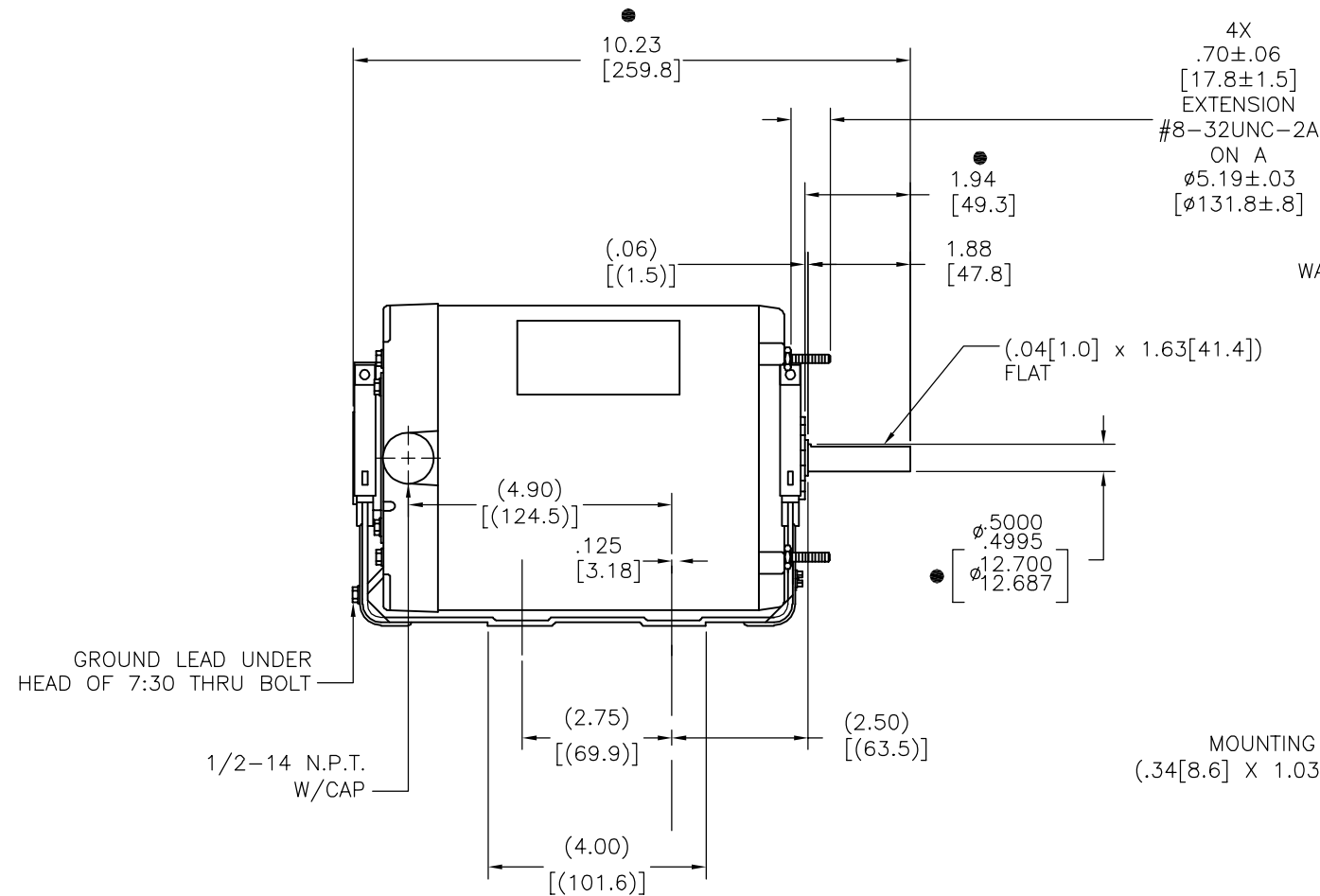

ALL DIMENSIONS SHOWN IN PARENTHESIS ARE REFERENCE DIMENSIONS. ALL OTHER DIMENSIONS ARE TOLERANCED PER THE FOLLOWING CHART UNLESS OTHERWISE SPECIFIED.

"C" DIM.	= +/- .055
SHAFT EXT.	= +/- .034
LEAD LENGTHS	= +/- 1.00
EXTENDED THRU-BOLTS	= +/- .050
ANGULAR DIMS.	= +/- 2 DEGS.

CATALOG MOTOR 922L

GEOMETRIC CHARACTERISTICS & SYMBOLS

- ▭ FLATNESS
- STRAIGHTNESS
- ∠ ANGULARITY
- ⊥ PERPENDICULARITY (SQUARENESS)
- ∥ PARALLELISM
- ROUNDNESS (CIRCULARITY)
- ⊘ CYLINDRICITY
- △ PROFILE OF ANY SURFACE
- ∩ PROFILE OF ANY LINE
- ↗ RUNOUT
- ⊕ TRUE POSITION
- ◎ CONCENTRICITY
- ≡ SYMMETRY

ASME Y14.5M 1994

UNLESS OTHERWISE SPECIFIED DIM. TOLERANCES ARE AS FOLLOWS:

INCH	±.1	±.02	±.005	±.0005
mm	±0.5	±0.13	±0.013	

ANG. ±.50 DEG
REMOVE BURRS & BREAK SHARP EDGES:
INCH .003-.015 mm 0.1-0.4
CORNER FILLETS TO:
INCH .020 mm 0.5
MACHINE SURFACES:
INCH 125 mm 3.2
METRIC DIMS. SHOWN IN [BRACKETS]

DR BY:

APPD:

THIRD ANGLE PROJECTION

EDS DATE 11-11-2011
FORMAT REV G

CONFIDENTIAL: THIS DRAWING AND ITS INFORMATION ARE THE EXCLUSIVE AND CONFIDENTIAL PROPERTY OF REGAL-BELOIT CORPORATION AND ARE NOT TO BE DISCLOSED, DUPLICATED, DISTRIBUTED OR OTHERWISE USED WITHOUT THE WRITTEN CONSENT OF REGAL-BELOIT CORPORATION. -ALL RIGHTS RESERVED.

REGAL-BELOIT CORPORATION

DESCRIPTION: OUTLINE

SIZE: C DWG NO: 1011615

SCALE: NONE SHEET: 1

4

3

2

1

REVISION:	ECO	REVISADO POR:	FECHA:	APROBADO POR:	FECHA:
D	0025402	O. CARVAJAL	04-13-2012	D. BALDERRAMA	04-13-2012

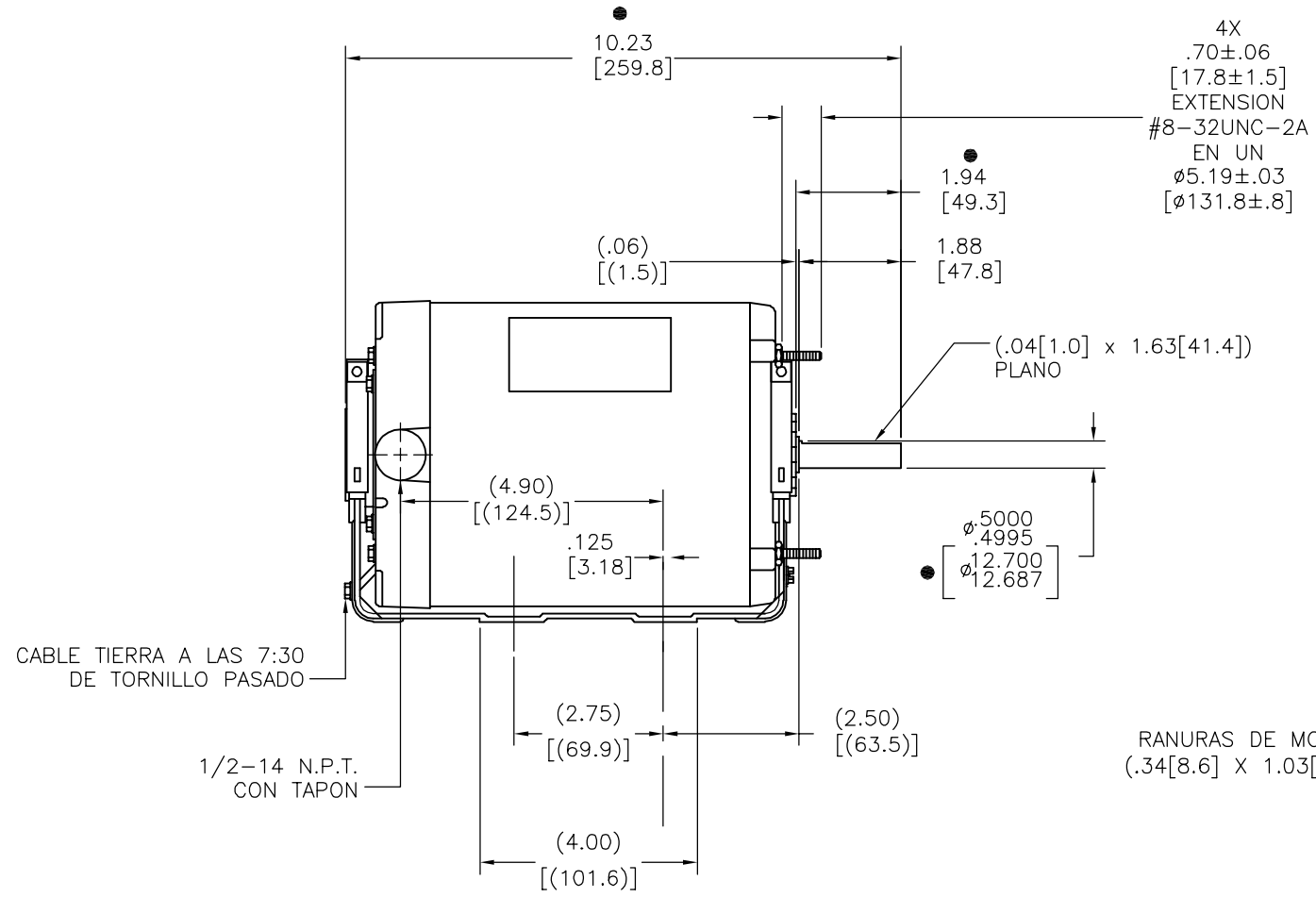

CABLE TIERRA A LAS 7:30 DE TORNILLO PASADO
1/2-14 N.P.T. CON TAPON

4X RANURAS DE MONTAJE (.34[8.6] X 1.03[26.2])

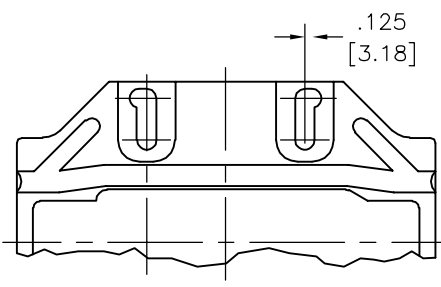
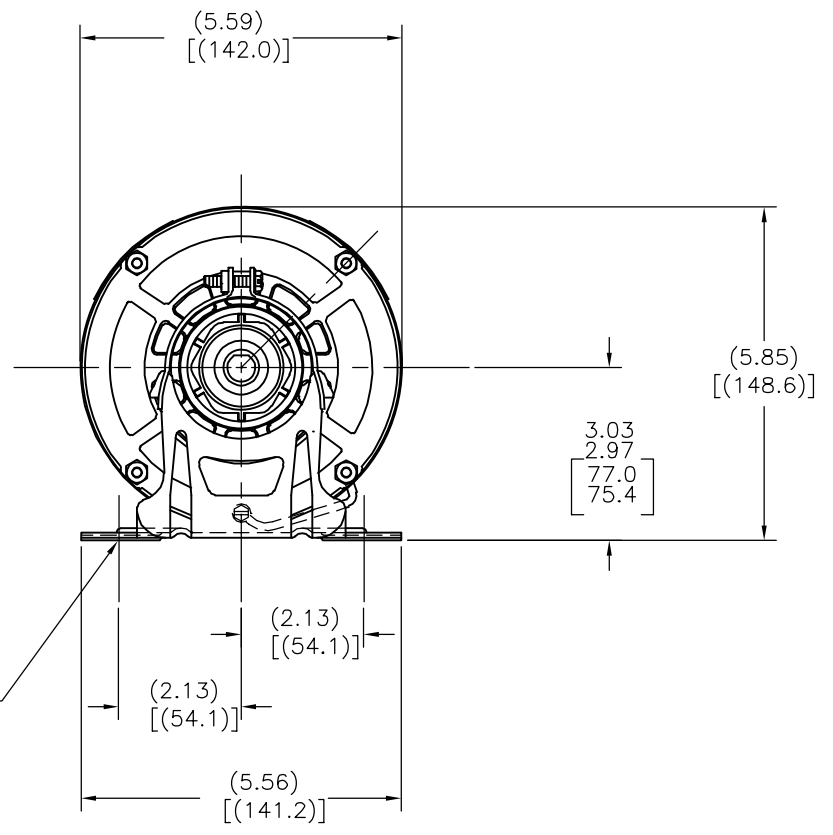

TODAS LAS DIMENSIONES MOSTRADAS EN PARENTESIS SON DIMENSIONES DE REFERENCIA. TODAS LAS DEMAS DIMENSIONES SON TOLERANCIAS DE ACUERDO AL SIGUIENTE CUADRO AL MENOS QUE SE ESPECIFIQUE DE OTRA MANERA.

DIM. "C"	=	±.055
EXTENSION DE FLECHA	=	±.034
LONGITUD DE CABLES	=	±1.00
EXTENSION DE TORNILLOS PASADOS	=	±.050
DIMENSION ANGULAR	=	±2 DEGS.

MOTOR DE CATALOGO 922L

CARACTERISTICAS DE GEOMETRIA Y SIMBOLOS ▽ PLANICIDAD - RECTITUD < ANGULARIDAD ⊥ PERPENDICULARIDAD (A ESCUADRA) // PARALELISMO ○ REDONDEZ (CIRCULARIDAD) ∅ CILINDRICIDAD △ PERFIL DE CUALQUIER SUPERFICIE ▲ PERFIL DE CUALQUIER LINEA ↗ VARIACION ⊕ POSICION REAL ⊙ CONCENTRICIDAD = SIMETRIA	A MENOS QUE SE ESPECIFIQUE DE OTRA MANERA, LAS TOLERANCIAS DE LAS DIMS; SON LAS SIGUIENTES: PULG ±.1 ±.02 ±.005 ±.0005 mm ±0.5 ±0.13 ±0.013 ANG. ±50 GRADOS ELIMINAR REBABAS Y ORILLAS FILOSAS DEL BORDE. PULG .003-.015 mm 0.1-0.4 FILETEAR ESQUINA: PULG .020 mm 0.5 MAQUINAR SUPERFICIES PULG 125 mm .32/	DIBUJADO POR:		DESCRIPCION: OUTLINE
		APROBADO POR:		
ASME Y14.5M 1994 DIMS METRICAS MOSTRADAS [PARENTESIS]		CONFIDENCIAL: ESTE DIBUJO Y SU INFORMACION SON PROPIEDAD DE USO EXCLUSIVO Y CONFIDENCIAL DE REGAL-BELOIT CORPORATION. Y NO DEBERAN SER REVELADOS, DUPLICADOS, DISTRIBUIDOS O USARSE DE OTRA MANERA SIN EL CONSENTIMIENTO ESCRITO DE REGAL-BELOIT CORPORATION. -TODOS LOS DERECHOS RESERVADOS.		TAMANO: C NUMERO DE DIBUJO: 1011615
		ESCALA: NONE		HOJA: 1

4

3

2

1

4

3

2

1

版本	ECO	编制	日期	批准	日期
D	0025402	O. CARVAJAL	04-13-2012	D. BALDERRAMA	04-13-2012

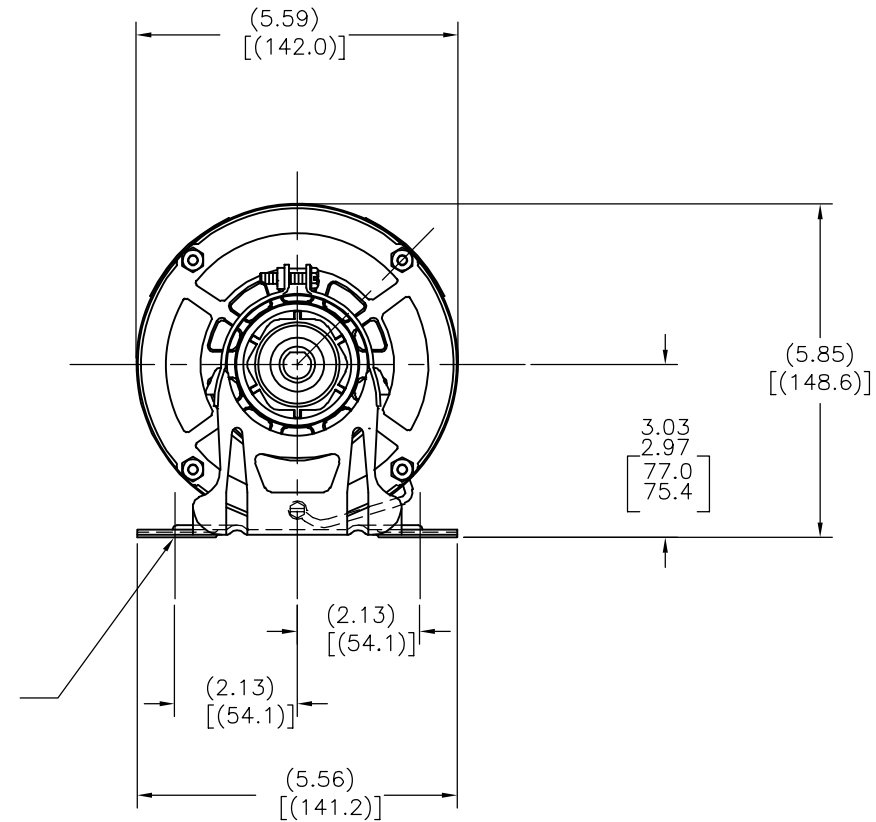
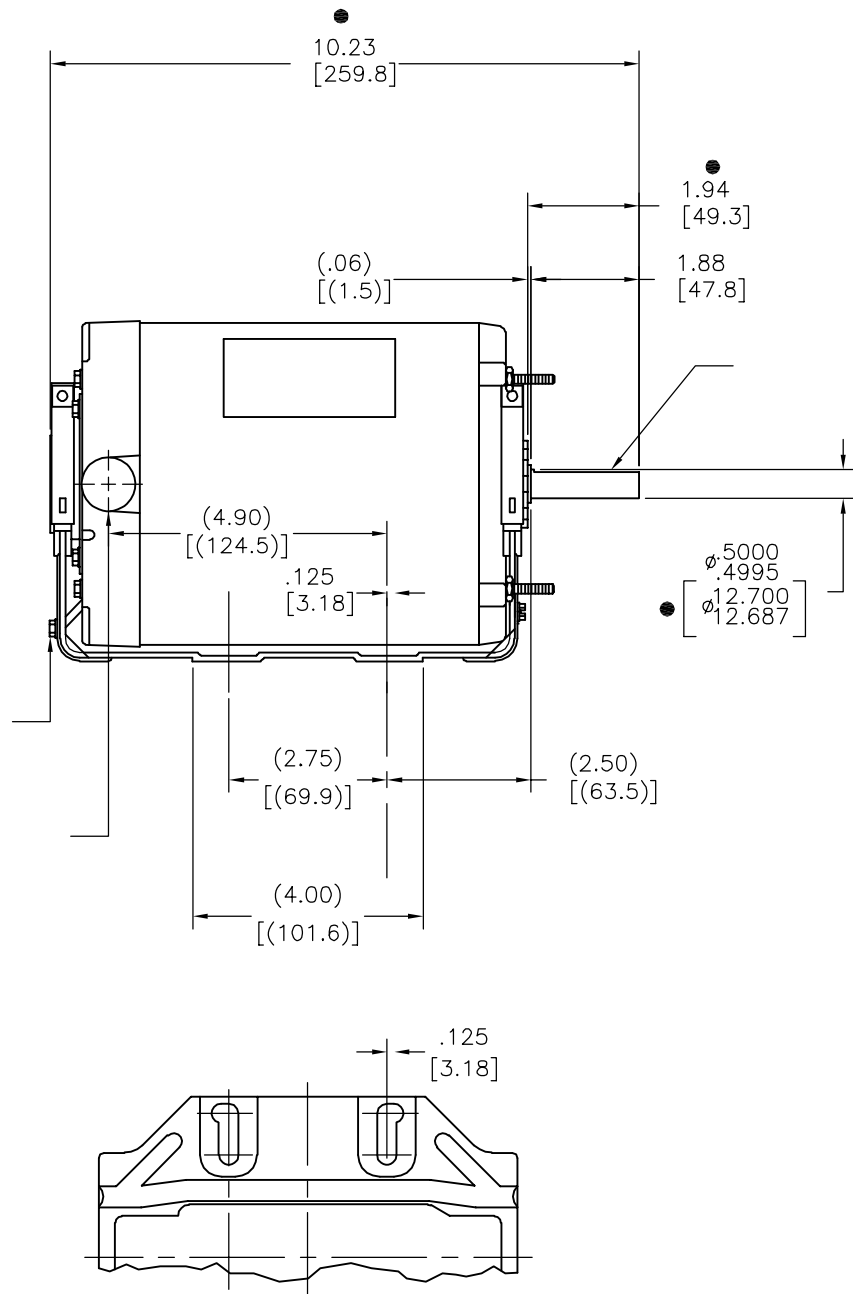

形位公差	除另有注明
□ 平面度	尺寸公差如下:
— 直线度	英寸 X XX XXX XXXX
∠ 倾斜度	英寸 ±.1 ±.02 ±.005 ±.0005
⊥ 垂直度	毫米 ±0.5 ±0.13 ±0.013
∥ 平行度	角度 ±.50 度
○ 圆度	清理毛刺和尖棱
⊘ 圆柱度	英寸 .003-.015 毫米 0.1-0.4
△ 面轮廓度	内圆角
∩ 线轮廓度	英寸 .020 毫米 0.5
↗ 圆跳动	表面粗糙度
⊕ 位置度	英制 125 米制 3.2
⊙ 同轴度	米制尺寸显示在 []
≡ 对称度	

ASME Y14.5M 1994

绘图:	
批准:	
第三角投影	
机密: 本图纸及相关信息所有权归REGAL-BELOIT CORPORATION. 未经REGAL-BELOIT CORPORATION书面授权, 不得泄露、复制、传播或作其他用途。一版权所有	图纸格式发布日期 11-11-2011 图纸格式版本 G



名称	OUTLINE	
图幅	C	图号 1011615
比例	NONE	页号 1

4

3

2

1