

- * FOR DIRECT COUPLING
- * COLOR:MUNSELL: RAL 5010
- * IP55

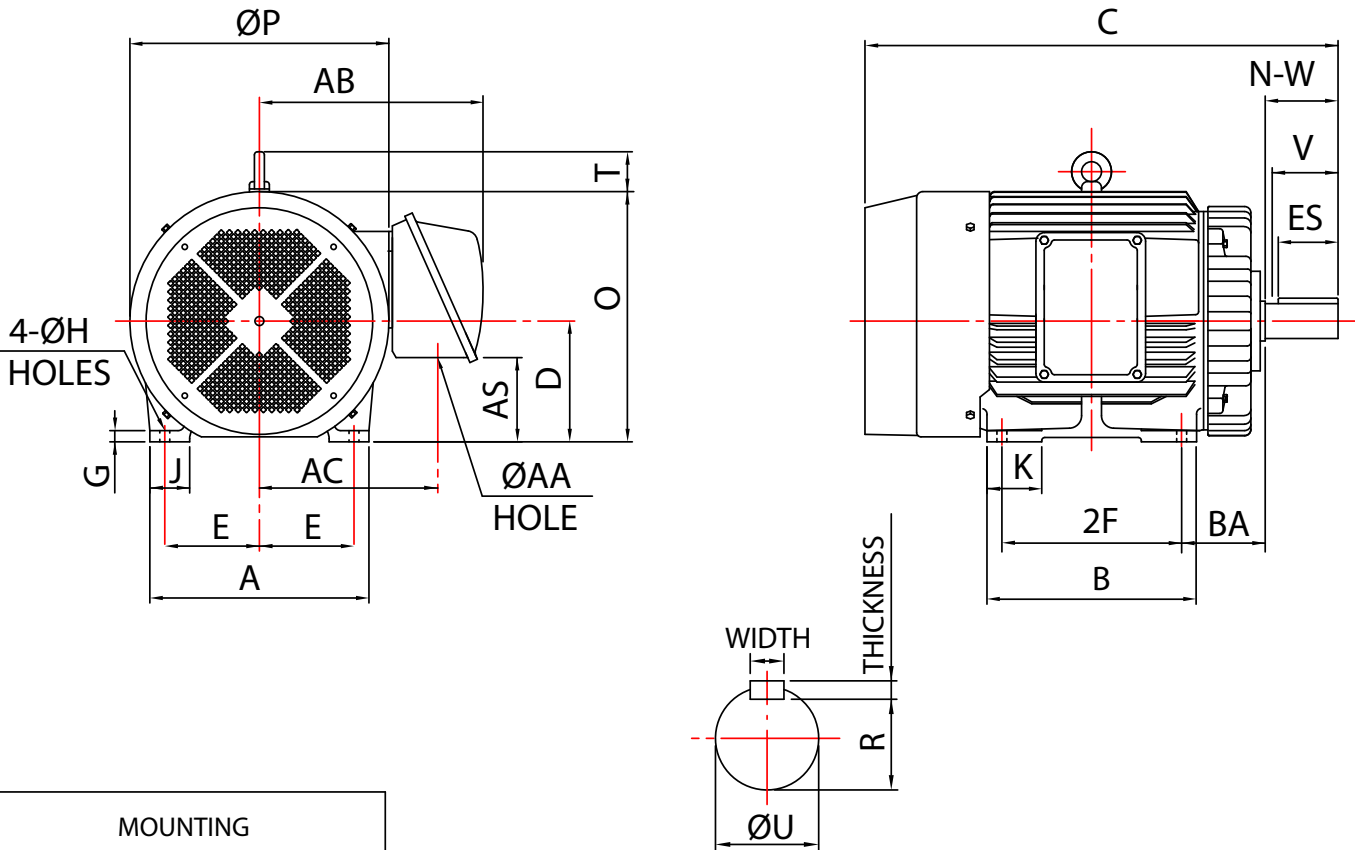

MOUNTING

E	2F	H	BA	A	B	C	D	G	J	K	P	AA	AB
6.25	12.00	0.66	5.25	14.88	14.17	31.32	8.00	0.91	3.15	3.15	17.32	NPT2"	14.37

AC	AS	O+T	KEY		ES	KEYSEAT R	SHAFT EXTENSION			BEARING NO.		APPROX WEIGHT
			WIDTH	THICK- NESS			N-W	U	V	D.E	O.D.E	
11.73	5.44	19.13	0.500	0.500	3.875	1.845	5.25	2.125	5.00	6312	6212	726Lb

- NOTE: 1. TOLERANCE OF SHAFT END DIAMETER U: +0.000,-0.001
 2. TOLERANCE OF SHAFT CENTER HEIGHT D: +0.000,-0.06
 3. DIMENSION R TOLERANCE: +0.000,-0.015
 4. DIMENSION V IS LENGTH OF STRAIGHT PART OF SHAFT.
 5. F CLASS INSULATION.

326T Footed