

- * FOR DIRECT COUPLING
- * COLOR:MUNSELL: RAL 5010
- * IP55

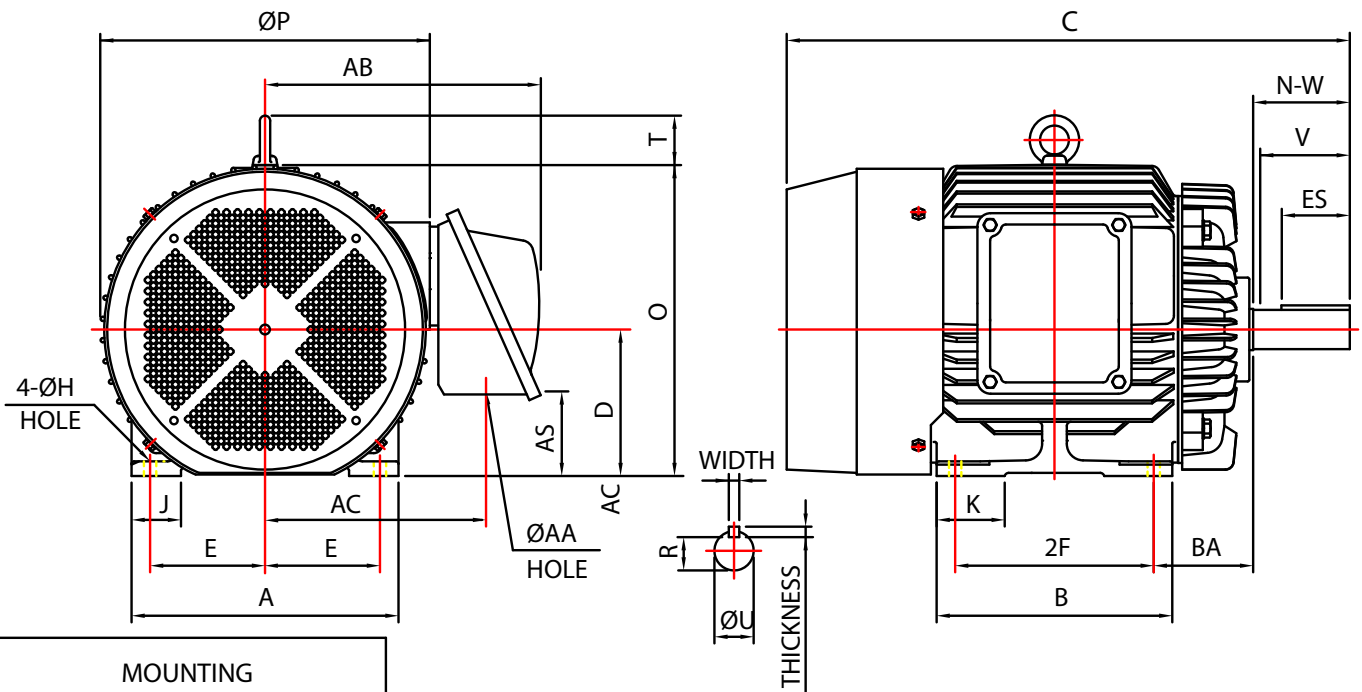

MOUNTING

E	2F	H	BA	A	B	C	D	G	J	K	P	AA	AB
5.50	9.50	0.53	4.75	12.76	11.26	26.9	7.0	0.79	2.36	3.25	15.75	NPT1.5"	13.4

AC	AS	O+T	KEY		KEYSEAT	SHAFT EXTENSION			BEARING NO.		APPROX WEIGHT	
			WIDTH	THICKNESS		ES	R	N-W	U	V		D.E
11.0	4.13	17.3	0.500	0.500	3.25	1.591	4.62	1.875	4.50	6310ZZ	6210ZZ	430 LBS

- NOTE:1. TOLERANCE OF SHAFT END DIAMETER U: +0.000,-0.001
 2. TOLERANCE OF SHAFT CENTER HEIGHT D: +0.000,-0.06
 3. DIMENSION R TOLERANCE: +0.000,-0.015
 4. DIMENSION V IS LENGTH OF STRAIGHT PART OF SHAFT.
 5. CLASS INSULATION.

284T Footed