

- * FOR DIRECT COUPLING
- * COLOR: MUNSELL RAL 5010
- * IP55

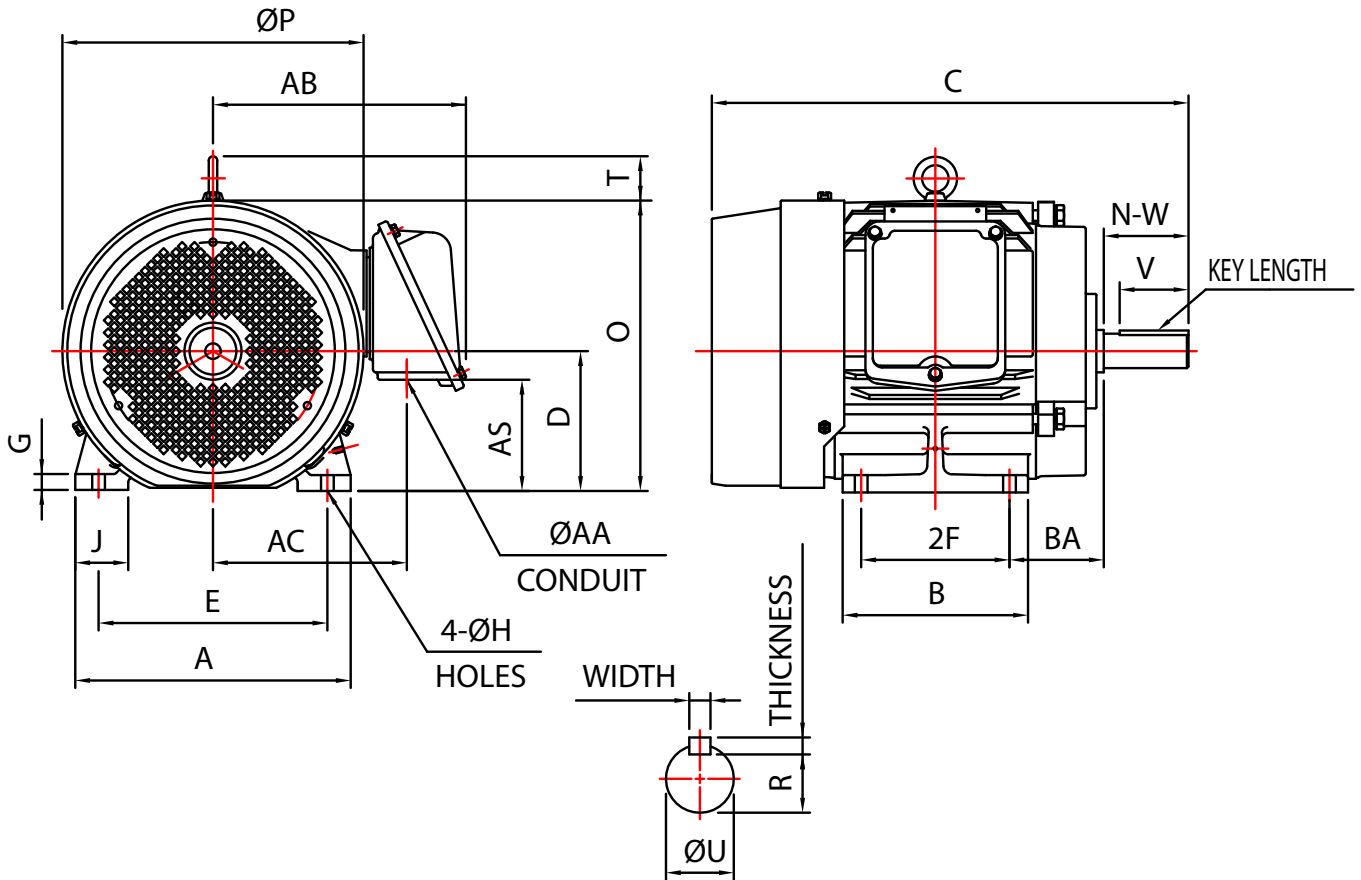

MOUNTING				A	B	C	D	G	J	O	T	P	AC
E	2F	H	BA										
4.25	7.00	0.41	3.50	10.23	8.39	19.43	5.25	0.65	1.97	10.48	1.65	11.20	7.20

KEY			KEYSEAT	CONDUIT BOX			SHAFT EXTENSION			BEARING NO.		APPROX WEIGHT (LBS.)
WIDTH	THICKNESS	LENGTH	R	AA	AB	AS	N-W	U	V	D.E	O.D.E	
0.312	0.312	2.375	1.201	NPT1"	9.29	4.13	3.38	1.375	3.30	6308zz	6208zz	187

NOTE: 1. TOLERANCE OF SHAFT END DIAMETER U: +0.000inch, -0.0005inch
 2. TOLERANCE OF SHAFT CENTER HEIGHT D: +0.00inch, -0.03inch

215T Footed